



Veri-Series Installation Guide

V-Prox / V-Flex / V-Pass / V-Smart / V-Station

Version 7.40

Trademark Disclosures

Bioscrypt has made every effort to provide disclosures when using trademarks owned by other companies. Trademarked designations appear throughout this publication. The publisher states that it is using the designations only for editorial purposes, and to the benefit of the trademark owner with no intent to infringe upon that trademark. The following trademarks are found in this manual:

- V-Prox™, V-Flex™, V-Pass™, V-Smart™, V-Station™, MV1100™, MV1200™ and MV-Lite™ are trademarks of Bioscrypt, Inc.
- Microsoft™, Windows 95™, Windows 98™, Windows NT™, Windows ME™, Windows 2000™, and Windows XP™ are trademarks of Microsoft Corporation.
- HID™ is a trademark of HID Corporation.
- MIFARE® is a registered trademark of Philips Electronics N.V.
- ***ICLASS™*** is a trademark of HID Corporation.

Disclaimer

The instructions in this document have been carefully checked for accuracy and are presumed to be reliable. Bioscript Inc. and its writers assume no responsibility for inaccuracies and reserve the right to modify and revise this document without notice.

It is Bioscript's goal to supply accurate and reliable documentation. If you discover a discrepancy in this document, please e-mail your comments to support@bioscript.com, or contact Bioscript Technical Support at the telephone number listed below.

No part of this publication may be placed in a retrieval system, transmitted, or reproduced in any way, including, but not limited to, photograph, photocopy, computer disk or other record, without prior agreement and written permission from:

Bioscript Inc.

5805 Sepulveda Blvd.

Suite 750

Van Nuys, CA 91411

Phone: 818-304-7180

Toll Free: 866-304-7187

Web: <http://www.bioscript.com>

Email: support@bioscript.com



NOTE: This symbol, found both on the device and throughout this manual, denotes a caution or warning. When this symbol is encountered during setup or installation, please be sure to first carefully read the corresponding section in this manual.

Bioscrypt One Year Limited Warranty Policy

Bioscrypt warrants to the original consumer purchaser ("Customer") that new Bioscrypt products will be free from defects in material and workmanship for one year from the date the product was shipped from Bioscrypt. For replacement products the warranty on the replacement unit is the remainder of the warranty on the original product or ninety (90) days, whichever is longer. The Customer is responsible for making any claims for shipment damage (evident or concealed) with the freight carrier. Bioscrypt must be notified within thirty days of shipment of incorrect materials.

If a defect is discovered, Bioscrypt's sole obligation shall be to repair or replace the Bioscrypt product(s) at its sole discretion at no charge, provided it is returned to Bioscrypt during the warranty period and is shipped freight and insurance prepaid. Merchandise must be properly packaged to prevent damage during shipping. Before returning a Bioscrypt product, contact Bioscrypt Technical Service to obtain a Return Material Authorization (RMA) number. No product may be returned whether in warranty or out of warranty without first obtaining approval from Bioscrypt. The model number, invoice number, and serial number may be required for warranty service.

This warranty shall not apply to any product or any part of a product, which in the judgment of Bioscrypt, has been subjected to misuse, negligence, alteration, accident, improper maintenance, or damage by excessive physical or electrical stresses. Tampering, such as opening the housing of a biometric reader or replacing parts will void this warranty. The warranty is void if the serial number of the Bioscrypt product has been defaced, altered, or removed or if the product has been modified. Repair and replacement parts will be furnished on an exchange basis and may be either reconditioned or new. All replaced parts or products become the property of Bioscrypt. This warranty may also be voided for failure to comply with Bioscrypt's return policy.

The warranty is not applicable to:

- Abnormal wear and tear
- Damage caused during installation
- Damage caused by the equipment or system with which the biometric reader is used
- Damage caused by modifications or repairs not made or authorized by Bioscrypt
- Damage caused by improper packaging
- Damage caused by lack of ESD protection
- Merchandise that is determined to be stolen

All Veri-Series units have an operating temperature range of 0°-60° Celsius (32°-140°

Fahrenheit). In addition, the Veri-Series product line has a relative humidity operating range of 0-95% non-condensing. Any device used outside that temperature or humidity range requires an enclosure with thermal or humidity control that can maintain a consistent environment within the stated operating ranges.

The newest Bioscrypt Veri-Series products are designed to be weather resistant but no sensor technology exists today that can work in all weather environments. If a Bioscrypt Veri-Series product is not used in a completely indoor environment, then a protective enclosure is required to shield the unit from moisture, dust, other contaminants and temperatures outside the stated operating range. Product failures resulting from exposure to the conditions are not covered under the product warranty.

For outdoor installations, Bioscrypt does offer an enclosure to protect the device from exposure to moisture, dust, other contaminants and temperatures outside stated operating range. To maintain the Bioscrypt warranty, the Veri-Series unit must be installed in a Bioscrypt certified outdoor enclosure. When used properly, this enclosure will protect Veri-Series devices in most environments, but not all. The Customer is responsible for determining whether the offered enclosure will appropriately shield Veri-Series devices in their specific installation. Product failures resulting from exposure to moisture, dust, other contaminants and temperatures outside stated operating range, even if an enclosure is used, are not covered under the product warranty.

This warranty is exclusive and in lieu of all others, whether oral or written, expressed or implied. Bioscrypt specifically disclaims any and all implied warranties, including without limitation, warranties of merchantability and fitness for any particular purpose. No Bioscrypt dealer, agent, or employee is authorized to make any modification, extension or addition to this warranty.

Bioscript Return Policy and Procedures

Bioscript must be notified within thirty days of the date that a defect is discovered. Bioscript will then issue a Return Material Authorization (RMA) number which the Customer must include with all correspondence and display on the outside of the shipping container when returning the product. Any products returned later than 30 days after issuance of an RMA may be subject to review as to whether the authorization to return is still warranted.

All Bioscript products must be shipped freight and insurance prepaid, in the original shipping container or equivalent. A written description of the defect together with a copy of the invoice and the name of the Dealer who sold the Bioscript product must be shipped with the product. All defects must be reproducible at Bioscript's location to qualify for this limited warranty.

For shipping addresses and return merchandise authorization contact Bioscript Technical Support. Warranty repairs do not re-initiate the warranty period. For repaired or replaced products the warranty on the replacement unit is the remainder of the warranty on the original product or 90 days, whichever is longer. All repairs are completed on a First-in, First-out (FIFO) basis.

Bioscript will return a repaired or replacement product via ground freight and insurance prepaid. If the Customer desires an airfreight or other expedited return shipping method, then they must agree to pay for the expedited shipping. Returned products that are found to be free of defects may be subject to a \$150.00 handling fee and will be returned at the Customer's expense.

Billable Repair Policy

By shipping product to Bioscript using the RMA provided by the Technical Support Department, you are agreeing to the following terms:

For all non-warranty repairs or billable repairs, the customer will be responsible for charges associated with parts, labor and shipping/freight to and from the Bioscript repair facility. Once the product is evaluated/inspected by a repair technician, Bioscript will provide the customer via e-mail with a written estimate of the aforementioned charges.

If any discrepancies arise between the final cost and the initial estimate, the customer will be notified.

The customer shall approve any estimate for non-warranty repairs or billable repairs and shall pay the estimated charges before the equipment is repaired. In the event the customer fails to either: (a) pay the estimated charges within 60 days of such estimate; or (b) arrange for return of the un-repaired equipment to the customer at

customer's cost, Bioscrypt will consider the equipment abandoned and will dispose of the equipment.

30 Day Return for Credit

Bioscrypt is a leading biometric company, specializing in fingerprint and verification systems. We are confident that customers will be pleased with Bioscrypt products. However, if you are not, and you purchased your merchandise directly from Bioscrypt, new products can be returned for credit within the first 30 days under the following conditions:

- You have received an RMA from Bioscrypt Technical Support and the item is returned in accordance with the Bioscrypt Return Policy and Procedures.
- Return Items are accompanied by proof of purchase.
- All original materials (accessories, manuals, CDs) are returned with the item.
- The item is in re-sellable condition. If there are any questions regarding re-sellable condition Bioscrypt will have the final decision as to whether an item can be returned, exchanged, and if a restocking fee will apply.

If you did not purchase your product directly from Bioscrypt Inc, please contact your retailer for their return policy.

Table of Contents

Veri-Series Installation Guide	i
V-Prox / V-Flex / V-Pass / V-Smart / V-Station	i
Version 8.11	i
Trademark Disclosures	i
Disclaimer	ii
Bioscrypt One Year Limited Warranty Policy	iii
Bioscrypt Return Policy and Procedures	v
Billable Repair Policy	v
30 Day Return for Credit	vi
Table of Contents	vii
Table of Figures	ix
Notes	x
Version Notes	1
Introduction	2
About the Veri-Series Products	3
About this Manual	6
Steps in a Comprehensive Installation	7
Planning the Installation	8
Component Selection	9
Mounting	10
Mounting Templates	11
Power Distribution & Device Hookup	14
Selecting the Right Power Supply	14
Device Hook-up (V-Prox/V-Flex/V-Pass/V-Smart)	15
Device Hook-up (V-Station)	16
Wiegand Connections	18
ESD Shield Earth Ground Requirement	18
RS-485	19
Ethernet (V-Station only)	19
TTL (V-Station only)	19
Cabling and Interconnection	20
When is an RS-485 network required?	20
When is an Ethernet network required?	21
RS-485 Cable Specification	21
Ethernet Cable Specification	22
RS-485 Network Topology	22
Ethernet Network Topology	23
RS-485 Cable Termination	23
Extending the RS-485 Specification	25
Connecting to the Computer	26
System Turn-Up Procedures	28

Device Configuration Check.....	28
Ground Potential Difference Check.....	28
General Installation Guidelines	30
Installation Issues:	30
Network Operation Issues:	30
Operational Issues:.....	31
Appendix A: Notices	32
FCC Information to Users	32
FCC Class B Digital Device or Peripheral - User's Notice (for all V-Station models only)	32
CE Information to Users	33
Warning to Users.....	34
V-Prox, A, H Information for Users*	34
V-Smart, A Information for Users	34
V-Smart, A, H Information for Users.....	34
V-Station, A, G Information for Users.....	35
V-Station, A, H Information for Users.....	35
V-Station, A, P Information for Users*	35
Appendix B: E.U. Certification Documentation	36
Restrictions of Use.....	36
V-Prox and V-Station Prox	36
V-Smart MIFARE, V-Smart iCLASS, V-Station MIFARE, V-Station iCLASS	36
Appendix C: R&TTE Kit Filter Installation.....	56
R&TTE Wiring Instructions for the V-Prox, A, H.....	56
R&TTE Wiring Instructions for the V-Smart, A and V-Smart, A, H.....	57
References	59
Bioscrypt Contact Information	61

Table of Figures

Figure 1: V-Prox / V-Flex / V-Pass	3
Figure 2: V-Smart	3
Figure 3: V-Station.....	4
Figure 4: Mounting Height	10
Figure 5: Mounting Procedures	10
Figure 6: V-Prox / V-Flex / V-Pass Mullion Mounting Template	11
Figure 7: V-Smart Mounting Template.....	12
Figure 8: V-Station Mounting Template.....	13
Figure 9: Rear Diagram of V-Station	18
Figure 10: Category 5 cable for RS-485/Ethernet Communications	22
Figure 11: Network Topologies - Star and Cascade (Daisy Chain)	23
Figure 12: Termination Options - Failsafe (a) and Passive (b).....	24
Figure 13: Common Installation Configuration - Power, Earth Ground, Wiegand and RS-485	24
Figure 14: Wring Diagram for RS-232/RS-485 Converter.....	25
Figure 15: Reader Wiring Schematic	25
Figure 16: V-Prox R&TTE Installation Kit Wiring Diagram	57
Figure 17: V-Smart R&TTE Installation Kit Wiring Diagram.....	58

Notes

Version Notes

Version 7.40: This release continues support for all products supported by V7.30, in addition to introducing some new functionality. For a list of changes in this release, please refer to the “MV1200 Product Notes – Release Notification” Document.

Version 7.30: All Veri-Series products are supported with this release, including the V-Station Prox, V-Station MIFARE, V-Station iCLASS, and V-Station Searching models.

Version 7.10: This version began support for Ethernet communication on all V-Station models.

Version 7.00: This is the first version released with the V-Station. Versions 7.00 – 7.20 are intended only for use on V-Stations.

Versions 5.20 – 6.xx: Please refer to the *MV1200 Release Notes* document for further information on changes from one version to the next. Version 5.20 and above are intended only for MV1200 based Veri-Series products.

Versions 1.0 - 3.30: These versions apply only to older MV1100 based products, and are not compatible with newer MV1200 based products. Version history for these versions may also be found in the *MV1200 Release Notes* document.

NOTE: Future versions of the Veri-Series hardware and software may be significantly different than described in this manual. Please make sure that you are using a manual that correctly coincides with the hardware version you are installing. Please contact Bioscrypt if you have any questions or visit www.bioscrypt.com to download updated documentation and firmware.

Introduction

Bioscrypt is proud to present the Veri-Series line of fingerprint authentication readers including the V-Prox™, V-Flex™, V-Pass™, V-Smart™, and V-Station™. The V-Prox™ includes integrated proximity reader and fingerprint verification. The V-Flex™ allows for upgrading existing installations and using other card technologies. The V-Pass™ doesn't require any cards or PINs, and searches through up to 200 fingerprints. The V-Smart™ incorporates contact-less smart card technology so that a hardwired network is no longer needed. Finally, the V-Station™, the most flexible of the group, offers convenient administration right from its console and now supports Ethernet. Select versions provide functionality found in each of the Veri-Series products, including a proximity or smart card reader, and searching ability.

Bioscrypt's product offerings leverage over 20 years of experience designing systems for the US Department of Defense. The company's mission is to bring their patented fingerprint verification technology, once found only in government or military applications, to a wide range of commercial applications around the globe at a reasonable cost.

The V-Prox, V-Flex, V-Smart, and V-Station readers prevent unauthorized access via loaned, lost or stolen proximity or smart cards by requiring that the fingerprint of the person seeking entry match the identity of the cardholder. Its ability to verify fingerprints in the face of adverse conditions like soil and other contaminants makes the Veri-Series readers useful for factories, plants, construction sites and similar environments that have previously been unable to implement biometric-based access solutions.

The V-Pass reader and V-Station searching version capitalize on this same fundamental algorithm for matching fingerprints but implement it in such a way as to be able to search through a database of templates to find the matching template. Therefore, these systems negate the need for cards at all, providing a convenient yet secure access control solution.

Fingerprint verification has been around for over 100 years, but during that time it has progressed from an intensive manual operation to an automated computer operation. The Veri-Series readers represent the state-of-the-art in fingerprint verification technology. It uses a 100% solid-state design. There are no moving parts, no optics or lenses, and it provides a variety of communications options.

About the Veri-Series Products

Bioscrypt's **V-Prox** (Figure 1) two-in-one solution combines a self-contained fingerprint verification package about the size of a business card (the MV1200), with an embedded proximity card reader. The two technologies are housed together in a modern case that conforms to mullion mount standards.

The **V-Flex** (Figure 1) provides all of the same capabilities of the V-Prox. Instead of having an embedded proximity card reader, the V-Flex requires an external Wiegand input from a card reader or keypad. Both the V-Prox and V-Flex store thousands of templates.

The **V-Pass** (Figure 1) reader does not use cards or PINs. By simply placing your finger on the sensor, the device will search through its database of hundreds of stored templates and respond via Wiegand to a door controller with the ID number of the user that matched the candidate image.

The **V-Smart** (Figure 2) provides all the capability of the V-Flex and includes an internal smart card reader (either MIFARE or iCLASS). Fingerprint templates are securely stored on a smart card and carried by the employee. The smart card is presented to the V-Smart and the template is read from the card and verified against the employee's live image. Storing the template on the smart card allows the V-Smart to have an unlimited user base, removing the need for a physically wired network.



Figure 1: V-Prox / V-Flex / V-Pass



Figure 2: V-Smart

The **V-Station** (Figure 3) is the first stand-alone version of the Veri-Series product line with an integrated keypad and LCD display. Many actions can be performed right from the console, thereby freeing users from having to administer the device from a PC. The standard version stores more than 3000 templates based on an ID entered on the keypad, but versions are available which include an enclosed proximity reader (V-Station A, P) or smart card reader (V-Station A, G and V-Station A, H). A searching version (V-Station A, S) is also available. In addition, this is the first product to offer built-in Ethernet support, and is by far the most flexible of the available devices.



Figure 3: V-Station

All of the Veri-Series readers are stand-alone or network readers that perform enrollment and verification and provide standard communication options that enable it to be easily incorporated into access control systems.

The response time is less than 5 seconds for fingerprint enrollment and less than one second for fingerprint verification. The system is compact, versatile, and can be configured in a variety of ways. The readers support the industry-standard Wiegand interface that can be used to connect to most any door controller or alarm panel. The unit supports RS-232 for administration through a PC connection, and it also supports RS-485 for multiple-unit operation and administration. The V-Station also supports administration over an Ethernet network.

The Bioscrypt products use the latest generation of solid-state (chip) fingerprint scanners or sensors. This type of sensor is being provided by a variety of electronics manufacturers. Veri-Series products are the only devices to be compatible with a variety of sensors, also called sensor interoperability.

The following paragraphs refer to operation and administration of the V-Prox device; however the same functions can be performed through the VeriAdmin software provided, or through the keypad on a V-Station.

The operation of the V-Prox is very simple: a user places or waves their card near the V-Prox unit, the unit prompts the user to place their finger on the sensor (communication is by means of a multi-colored LED), the V-Prox then reads the fingerprint and compares it to a stored record of the user. If the comparison yields a high degree of match, the user fingerprint is accepted and the user's ID number is transmitted to the access control unit over the Wiegand connection. If the match fails, then either nothing is sent to the controller or a failure code is sent so that the

controller can log failed access attempts. The controller unlocks the door for the user if the user has access. Therefore, the procedure is simple: present a card, place finger, and open the door. The whole process takes less than 5 seconds.

Administration of the V-Prox is also simple. Any number of cards can be set up as Enroll or Delete cards. These cards are maintained by the system administrator(s) responsible for the access control system (one or more cards can be kept off-site for added safety). To enroll a new user within a V-Prox unit, present an Enroll card, verify the fingerprint of an authorized Enroller, present an unused card, and finally place the finger of the user on the system. The user is now enrolled in this V-Prox unit. If the installation has multiple V-Prox units you will have to either repeat this enroll process on other units or use software (if the units are connected via a RS-485 or Ethernet network) to transfer the templates. The User ID will also have to be added to the access control system. Deleting a user from the V-Prox is just as easy – just use the Delete card instead of the Enroll card and follow the same procedure.

All Veri-Series products also include an auxiliary port in the bottom of the unit. This auxiliary port supports RS-232 communications with a host computer. You can use this port to transfer templates, manage enroll and delete cards, etc.

An additional Ethernet port is now available on V-Station products, enabling administration and template management over an Ethernet compatible network, using the VeriAdmin software.

About this Manual

This manual provides a simple step-by-step procedure for defining the RS-485 or Ethernet network that will be used to communicate to a number of Veri-Series readers as well as making connections to those readers. The Veri-Series Operation Manual (under different cover) will provide the user or installer with information required to configure the readers for communications on an RS-485 or Ethernet network and for making other configuration changes such as for Wiegand format.

The V-Prox, V-Flex, and V-Pass readers are designed to be compatible with mullion mount applications. Mullion mounting is not required, however, and the readers can be mounted on any flat surface. The installer will want to take into account codes and ordinances that affect the installation. The readers can also be mounted on a single gang electrical box. Bioscrypt provides both a narrow and a trimmed out wall plate for these applications.

Bioscrypt offers a *Veri-Series Operations Manual* under a separate cover. This guide describes in complete detail the administration and day-to-day operation of the Veri-Series unit. Bioscrypt also offers a *Veri-Series Setup Guide*, a quick step-by-step guide for initial Veri-Series setup and use. Both of these are included on the installation CD.

Steps in a Comprehensive Installation

Every installation is unique. In some cases, the issues are well understood and can be handled in a standard fashion. In other cases, there are issues that are specific to the installation, and may not be immediately recognizable. This document attempts to address many of the issues that you will be faced with during installation. The steps for a successful installation are:

- **Planning the installation** – outlining the different components in the installation, determining the interconnections between different components, identifying issues specific to the installation
- **Component selection** – deciding on the right Veri-Series product(s) to use, choosing a door controller, which type of proximity or smart cards to use, which type of PC to use (optional, except for V-Pass), etc.
- **Mounting** – proper mounting hardware and location must be chosen in accordance with applicable regulations as well as desired esthetics and convenience
- **Power Distribution / Device hook-up** – proper power must be supplied to each unit and consideration must be given to using UPS, avoiding interference, proper grounding, etc.
- **Cabling and Interconnection issues** – the topology, type of network, and type of cable used will be determined by requirements such as number of units, distance between units, data throughput, etc. Each device on the network must be assigned a unique ID (and IP address for Ethernet) to avoid communication collisions
- **Power-up procedure** – units should be brought up one at a time in a thoughtful sequence to help trouble-shoot any problem areas

The following sections will provide more information on each of these steps.



WARNING. A qualified technician must install veri-Series devices.

Planning the Installation

Planning the installation is probably the single most important aspect to a successful installation. Good planning will be comprehensive, accurate, and adaptable. Planning for an Access Control installation must consider: the access controller, the door locks, and the readers. Readers provide a means for the users to request access to a controlled area. The Veri-Series products are different from typical readers in that they provide not only verification of the presence of an authorized card, but also the assurance that the authorized holder is presenting the card.

During the planning phase, you should determine:

- How many doors need to be protected
- What type of reader on each door (maybe some doors are internal and don't require the added security of the Veri-Series)
- If multiple Veri-Series units are to be networked, a dedicated PC is recommended to administer the system. This can be done through RS-232 (primary or auxiliary ports), RS-485, or via Ethernet (V-Station only).
- The controller must support any of the Wiegand formats supported by the Veri-Series units.
- If the installation requires RS-485 or Ethernet network cabling for template distribution/management

When planning the system, identify all wiring by the signal levels they are to carry. Wires can be generally separated into the following groups:

1. Power distribution: Wires carry power to devices, door strikes, etc.
2. Data communication: RS485, RS-232, Ethernet, Wiegand, etc.
3. Sensor: Door contact, request to exit push button, alarm input, etc.

Use separate cable/conduit for different signal groups to avoid cross talk. Observe the distance limitation of each type of signal when planning device placement. Line extenders or repeaters can be used for extended distances when required.

Do not run any wires near utility AC power wiring, lightning rod grounding wire, etc. to avoid externally generated transients. Grounding equipment is required for ESD protection and safety.

Do research on the environment where the equipment will operate. If used outdoors, it may be necessary to seal the readers or protect the installation with a weather shield.

Component Selection

Component selection will be based on customer demands and requirements. We are glad that you are considering or have selected Bioscrypt products as part of your system integration. We hope that you find the readers to be easy to use while offering an unparalleled level of security.

The readers do not have built-in relays that would allow them to control a door lock, and therefore, they must be part of a larger system such as a door control system. Each of the Veri-Series readers offers RS-232 and RS-485 communications channels for communicating with a PC or host controller. In addition, the V-Station supports communication via a 10base-T Ethernet port. Each reader also uses the Wiegand protocol to interface with Access Control equipment such as door controllers (outputs) or additional readers (inputs).

Therefore, a minimum system would consist of a fingerprint reader unit mounted on or near a door mullion, an electric lock, and the door controller. More complex systems may consist of readers on multiple doors, each door with an electric door lock, a multi-door controller, and a PC to run the door controller and Veri-Admin management software. Some installations will require anti-passback capabilities, and these will typically use standard proximity card readers (compatible with the V-Prox system) on "request to exit".

In addition to the hardware components, the installation will contain proximity or smart cards, cabling, and will likely include a PC, an RS-232/RS-485 converter, and software. Equipment for setting up an Ethernet network may also be needed, including, hubs, switches, network cards, etc. Some installations may wish to utilize a database or custom software for template management and access scheduling.

Mounting

The readers can be mounted to any flat surface. The following describes the V-Prox/V-Flex/V-Pass mounting, but the same concept applies to mounting the V-Smart and V-Station (except for mullion mounting).

The mounting plate is 2 inches wide, which is suitable for mounting in a door mullion. The mounting plate hole pattern is also compatible with single gang box mounting. The pigtail protruding from the rear of the unit is for connecting the reader to the rest of the system.

Factors in determining the position of the reader on the wall should include mounting in-line with other switch plates or fixtures, approximately 54 inches from floor to top of unit (see Figure 4), mounted on knob-side of door, and in accordance with Americans with Disabilities Act.

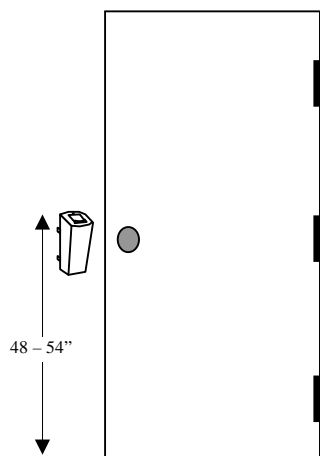

Figure 4: Mounting Height

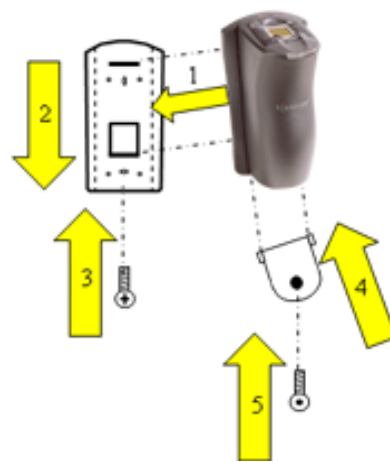

Figure 5: Mounting Procedures

Reader mounting is very simple. The mounting plate is attached to the wall or mullion using screws and anchors to secure it in place. The reader body has two tabs that slide into the wall plate. Use the following procedure (illustrated in Figure 5):

1. Align reader body with wall plate
2. Slide reader body down, locking tabs into wall plate
3. Set reader body in place with Phillips-head #4-40 screw
4. Attach Aux. port door to bottom of reader with a twisting motion
5. Secure door to reader with pin-in-hex #6-32 screw

All of the readers in the Veri-Series line are constructed out of durable ABS plastic. The mounting plate is also constructed out of ABS plastic. This system provides for a very lightweight, yet sturdy system.

Mounting Templates

- For mounting into wall anchors, wood or sheet metal use #4 flat head screws (<0.125 inch thread width, <0.250 inch head width).
- For mounting onto gang box, use #6-32 machine screws with flat head.

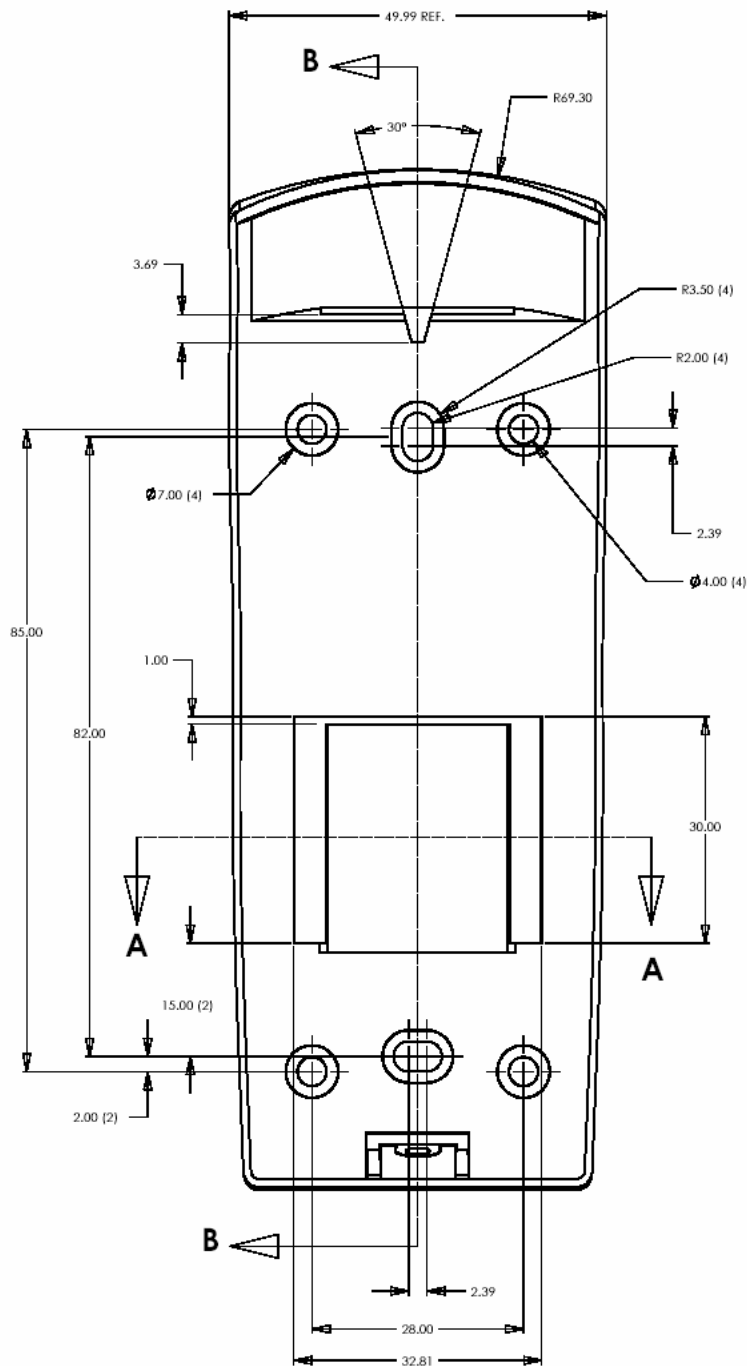

Figure 6: V-Prox / V-Flex / V-Pass Mullion Mounting Template

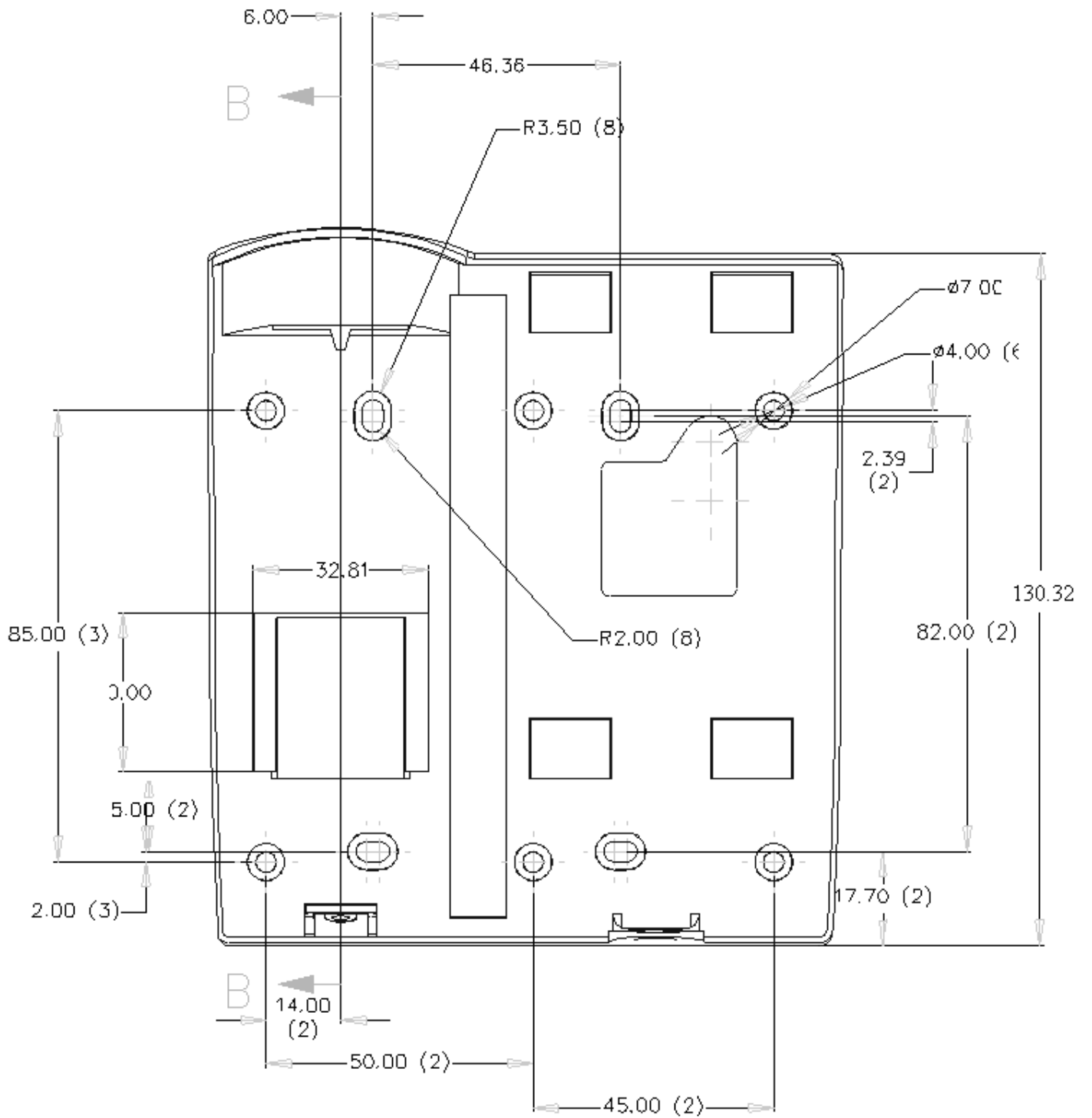

Figure 7: V-Smart Mounting Template

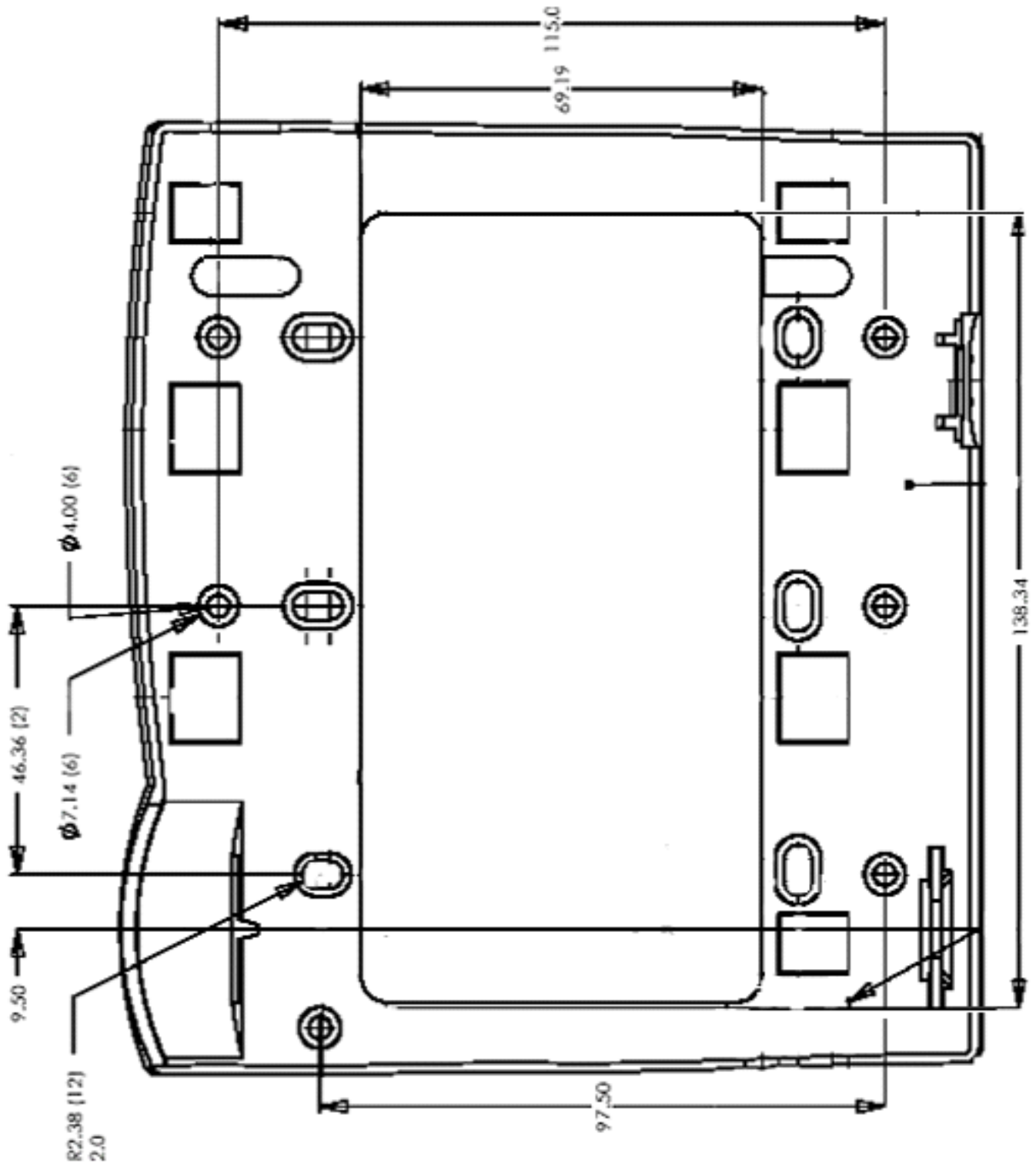

Figure 8: V-Station Mounting Template

Power Distribution & Device Hookup

The Veri-Series product as well as other components in the system will rely on power provided to the system for operation. In a small installation, power may be provided by means of an AC adapter placed near the V-Prox reader itself. In larger installations, power will be distributed from either a central source or various sources.

Power to the Veri-Series units should be:

- Isolated from other equipment
- Filtered
- Protected by means of a uninterruptible power supply (UPS) or battery backup
- If transients are an issue in the installation, a transient voltage suppression device is also recommended

When planning a system, know the power requirement of each device. If multiple devices are to share a common power supply, care must be exercised to avoid excessive voltage loss on the wires. Voltage loss can lead to communication problems when devices are talking and/or listening on different ground references.

Voltage loss is directly proportional to wire resistance and the current the wire carries. Place the power supply as close to the equipment as possible. Select appropriate wire size for the load. The Veri-Series readers run on DC power between 9 and 24 VDC (V-Smart operates between 9-12V DC and V-Station between 12.5-24V DC). Power requirements are as listed in Table 1.

	V-Smart (all models)	V-Prox /V-Flex / V-Pass	V-Station (all models)
Power Requirement:	5 Watts	5 Watts	5 Watts
Input Voltage Range:	9-12VDC	9-24 VDC	12.5-24 VDC
Peak Current:			
12 VDC	400mA	400 mA	500mA
24 VDC	N/A	200 mA	200mA
Current at 12 VDC:			
Verification	300-400 mA	300-400 mA	300-400 mA
Idle (non V-PASS)	160 mA	60 mA	300 mA
Idle (V-Pass)	N/A	150-200 mA	N/A

Table 1: Veri-Series Power Requirements

Selecting the Right Power Supply

Most power supplies in the market today provide good input/output isolation, however those which do not provide isolation (or have hit leakage capacitance), coupled with accidental AC power lines interchange, present serious ground fault

problems for installers. With ground fault, the signal reference between subsystems may be 115 VAC apart. If these subsystems are interconnected, the large potential difference will cause equipment damage or personal injury. We recommend use of isolated power supplies only.

All factory supplied power supply assemblies are either switching or regulated linear supplies and are isolated for safety and to minimize ground loop problems.



WARNING. Use only a UL-Listed Class II power supply rated at 12 VDC, 500mA.

Device Hook-up (V-Prox/V-Flex/V-Pass/V-Smart)

The readers are connected to other components of an integrated system through the pigtail wire bundle that protrudes from the rear of the unit. This wire bundle is made up of the connections described in Table 2.

Pin #	Signal Description	Original Cable (Gray Jacket)	New Cable (Blue Jacket)
1	Wiegand Out Data 0	Red/Black	Green
2	Wiegand In Data 0	Green/Black	Green/White
3	Wiegand Out Data 1	Orange	White
4	Wiegand In Data 1	Orange/Black	White/Black
5	Line Trigger	Green	Gray
6	Wiegand GND	Red	Black/White
7	RS-485 (-)	Blue/Black	Blue/Black
8	RS-485 (+)	White	Blue
9	RS-232 TX (N/A on V-Smart)	Black/White	Violet
10	RS-232 Rx (N/A on V-Smart)	Red/White	Violet/White
11	Power GND	Black	Black
12	Signal GND	Green/White	Black/Red
13	Power Input 9-12VDC (V-Smart) 9-24VDC (V-Prox, V-Flex, V-Pass)	Blue/White	Red
14	Reserved	Blue	Red/White
15	Safety GND	White/Black	Green/Yellow

Table 2: Veri-Series Pigtail Connections



WARNING. The RJ-11 connector is intended for RS-232 communication only! Any attempt to connect it to a phone line will damage the unit.

Device Hook-up (V-Station)

The V-Station readers do not have a pigtail wire bundle as do the other Veri-Series products. Connections are made using RJ-45/RJ-11 or Weidmuller connections. Table 3 and Table 4, shown below, describe V-Station’s connections while Figure 9 shows the layout on the back of the V-Station.

Group	PIN	Signal
Ethernet RJ-45	1	Receive +
	2	Receive -
	3	Transmit +
	4	NC
	5	NC
	6	Transmit -
	7	NC
	8	NC
RS-485 RJ-45	1	Transmit +
	2	Transmit -
	3	Ground
	4	Receive +
	5	Receive -
	6	NC
	7	NC
	8	NC
RS-232 RJ-11	1	TX
	2	RX
	3	RTS*
	4	CTS*
	5	Ground
	6	NC

Table 3: V-Station Ethernet, RJ-45, and RJ-11 Connections

*Not connected but may be used in the future.

Pin	Group	Label	Signal Description
8-Pin Connector:			
1	RS-485	TX(+)	Transmit +
2		TX(-)	Transmit -
3		RX(+)	Receive +
4		RX(-)	Receive -
5		GND	RS-485 Signal Ground
6	RS-232	GND	RS-232 Signal Ground
7		TX	Transmit
8		RX	Receive
3-Pin Connector:			
1	Power/Ground	+(POS)	12.5* – 24 VDC +
2		-(NEG)	12.5* – 24 VDC -
3		EGND	Earth Ground
12-Pin Connector:			
1	Wiegand	IN 0	Data 0 In
2		IN 1	Data 1 In
3		OUT 0	Data 0 Out
4		OUT 1	Data 1 Out
5		LED IN	LED In
6		LED OUT	LED Out
7		GND	Wiegand Ground
8	TTL (IN)	IN 0	TTL Data 0 In
9		IN 1	TTL Data 1 In
10	TTL (OUT)	Out 0H	TTL Data 0 Out
11		OUT 1L	TTL Data 1 Out
12		GND	TTL Ground

Table 4: V-Station Weidmuller Connectors

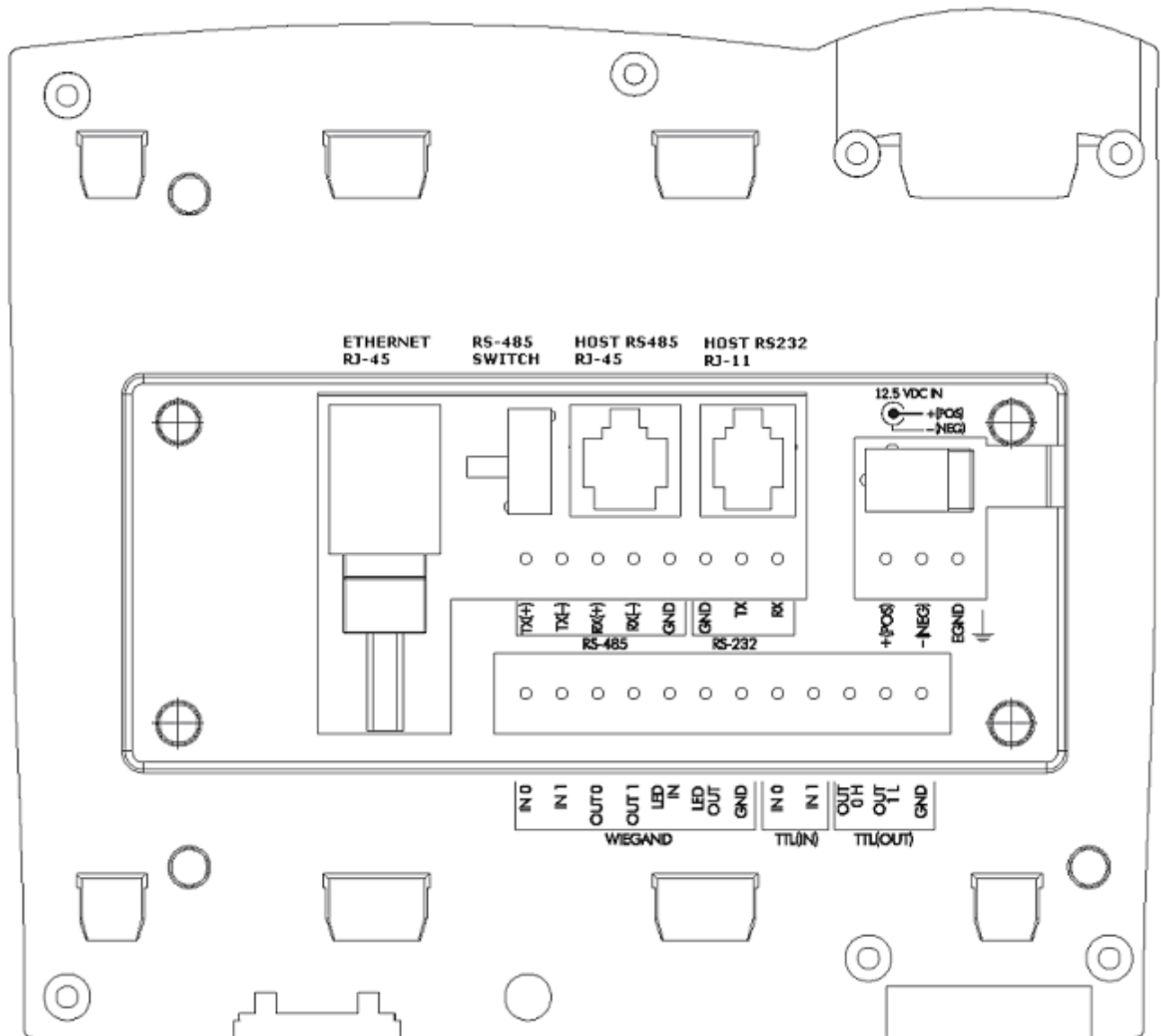

Figure 9: Rear Diagram of V-Station

Wiegand Connections

Wiegand output lines should be connected to the Wiegand compatible controller. When connecting Wiegand output to a controller, you must make that connection using Data0, Data1, and a common Ground reference. Wiegand input lines can be used for an alternate Wiegand input device (this connection is required for the V-Flex device).

ESD Shield Earth Ground Requirement

The Finger mask (conductive plastic surrounding the fingerprint sensor) is sometimes referred to as an ESD Shield. Pin 15 on the Pigtail (EGRND on the input/earth-ground

connector for V-Station) is connected to the ESD shield of the fingerprint sensor. This should be connected in such a way as to make a low-impedance connection to Earth ground. **DO NOT CONNECT THE SHIELD TO POWER GROUND.** Improper connections will potentially create ground loops that may cause damage to the Veri-Series and other equipment. Furthermore, neglecting to provide a path for ESD to Earth ground puts the electronics at risk if ESD is discharged into the unit from a user.

RS-485

RS-232 and RS-485 are used for communication with a PC running Veri-Series compatible software (such as our VeriAdmin software). RS-485 connections among various readers should be made by connecting the (+) and (-) lines of the differential RS-485 in a daisy chain manner. For instance, from V-Prox to V-Prox, the (+) line from one V-Prox is connected to the (+) line of the next V-Prox and so on; likewise for the (-) lines. Additionally, connect the grounds from each V-Prox unit back to the signal ground connection for the PC.

Ethernet (V-Station only)

The RJ-45 Ethernet connector can also be used for communication with a PC running Veri-Series compatible software (Version 5.10 and above). Standard Ethernet patch cables may be used, but care must be taken to identify straight-through cables versus crossover cables. To wire a V-Station directly to a PC NIC card, a crossover cable must be used. For connecting multiple V-Stations together on an Ethernet bus or directly to a switch or hub, straight-through cables should be used.

TTL (V-Station only)

The V-Station reader shall include General Purpose Input/Output connections. These connections shall be standard TTL Logic lines. The TTL Out 0H line is capable of sourcing a low-current signal. The TTL Out 1L line is capable of sinking a low-current signal. The TTL functionality shall be enabled by default, but can be disabled using the VeriAdmin software or the Administrative Mode. For more information on this feature please contact Bioscrypt Technical Support.

Cabling and Interconnection

Cabling may seem to be a trivial aspect to the installation, requiring nothing more than planning the cabling route and pulling the cable through the building. This is true for Wiegand and power wiring considerations; however, if your installation requires the use of RS-485 or Ethernet communications, then the choice of cable, the cable run length, the network topology, and termination of the network may be very important aspects that must not be overlooked.

Spec	RS-485	RS-232
Mode of Operation:	Differential DC Coupled	Single-ended DC Coupled
DC Isolation:	No	No
Max. Distance:	4000 ft.	150 ft.*
Number of Devices on one line:	32	2
Max. Data Rate	56 kbps	56 kbps*
*RS-232 communications distances are dependent on baud rate (bps). For example, at 9600 baud, a distance of 100 ft. is possible with shielded cable, but at 56k baud (kbps) a maximum of 20 ft. is recommended.		

Table 5: RS-485 / RS-232 Communications Comparison

Parameter	10 Mbps	100 Mbps	1000 Mbps
Maximum collision diameter, DTE to DTE	328 ft. UTP	328 ft. UTP 1352 ft. fiber	328 ft. UTP 1037 ft. fiber
Maximum collision diameter with repeaters	8202 ft.	673 ft.	656 ft.
Maximum number of repeaters in network path	5	2	1
Maximum number of devices on one line	255	255	255
Maximum Data Rate*	*V-Station supports only 10BaseT (10 Mbps); internally, the product is still limited to 56K or 115K bps		

Table 6: Ethernet Comparison

When is an RS-485 network required?

RS-485 is a networking specification similar to Ethernet, which is used for computer networks. RS-485 is different from Ethernet and is not compatible with modern computer networks. This means that you cannot connect most Veri-Series units directly up to Ethernet networks. The V-Station does however support Ethernet.

RS-485 has two distinct advantages over the more common RS-232. First, it allows you to connect up to 31 Veri-Series units to a PC (the PC will either need internal support for RS-485 or will require an external RS-232/RS-485 converter available from Bioscrypt). Second, the RS-485 specification allows for cable run lengths up to 4000

feet (1200 meters) at modest baud rates.

An RS-485 network will need to be implemented in the following circumstances:

- There are multiple readers that must be connected together so that templates can be distributed among the units
- There is only a single reader, but it is over 100 feet (30 meters) from the host PC.

When is an Ethernet network required?

Ethernet is a networking specification now used all over the world for computers, IP phones, and other devices. The only Bioscrypt product that currently supports this standard is the V-Station. Ethernet has many advantages over an RS-485 network, namely, faster data transfer rates over greater distances. However, the prime advantage to your network of Bioscrypt readers will be the ability to connect many more units, enjoy easier configuration from the PC, and avoid conflicts when multiple units transmit at the same time (i.e., if two or more units have the same unit ID). Care must be taken to ensure the security of V-Stations placed on a network that is also shared by PCs other than the administration machine or other peripherals.

RS-485 Cable Specification

The Veri-Series readers provide a 2-wire, half-duplex RS-485 interface. The main run cable should be low capacitance, twisted pair cable, with approximately 120-ohm characteristic impedance. Category 5 rated communications cable is used in Ethernet networks. This cable is typically 24 AWG (solid), unshielded, twisted-pair with a shunt capacitance of approximately 17 pF/ft and characteristic impedance of 100 – 120 ohms. This is the recommended cabling for RS-485 communications. In certain electrically noisy environments, a shielded cable may be required.

Spec	Recommendation
Capacitance (conductor to conductor)	<20 pF/ft.
Characteristic Impedance	100 – 120 ohms
Nominal DC resistance	<100 ohms/1000 ft.
Wire gauge	24 AWG stranded
Conductors/Shielding	>2 pair (shielded optional)

Table 7: Recommended Cable Characteristics

It is often hard to quantify if shielded cable is required in an application or not. Since the added cost of shielded cable is usually minimal it is worth installing the first time.

The total length of the communication cable (adding up all of the segments of the run) must not exceed 4000 ft (1200 m) as outlined in the specification for RS-485 (see reference 3).

Although the RS-485 specification calls out a maximum cable length of 1200 meters

and a maximum baud rate well above that of the Veri-Series reader, a more conservative system should be configured for no more than 1000 meters and running at a baud rate of 9600 bits per second. After the network is configured and is running in a stable manner, the baud rate can be increased if faster network communications are desired.



Figure 10: Category 5 cable for RS-485/Ethernet Communications

Drops (down leads) to equipment are not recommended, but if required, should not exceed 10 feet and should use the same cable recommended above.

Ethernet Cable Specification

Ethernet cables should generally be shielded Category 5 or better. The V-Station supports only 10Base-T Ethernet. Therefore, it only makes sense to use cable for faster Ethernet varieties (such as gigabit) if PCs or other peripherals are to be placed on the same network.

With most Ethernet networks, straight-thru cables should be used. However, in the event of a single reader-to-PC network, a crossover cable must be used. There are other special considerations for such a network. Please see the next section on connecting to the computer.

RS-485 Network Topology

Communication cables for RS-485 should be laid out in a daisy chain. See Figure 11. Long stubs (T connections) should be avoided because they create discontinuities and degrade signal quality. If the stub is long, a signal that travels down the stub reflects to the main line after hitting the input impedance of the device at the end of the stub. This impedance is high compared with that of the cable. The net effect is degradation of signal quality on the bus. Keeping the stubs as short as possible avoids this problem. Instead of adding a long-branch stub, loop the main cable to the device you wish to connect.

DO NOT connect devices in a STAR configuration – this creates long stubs and is a cause for concern. This configuration usually does not provide a clean signaling environment even if the cable runs are all of equal length. The star configuration also presents a termination problem, because terminating every endpoint would overload the driver. Terminating only two endpoints solves the loading problem but creates transmission-line problems at the un-terminated ends. A true cascade or

daisy chain connection avoids these problems.

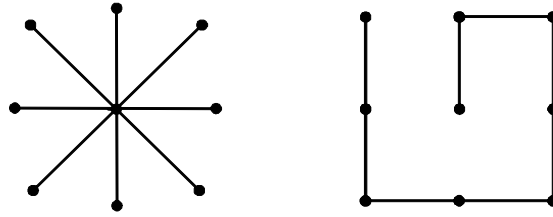

Figure 11: Network Topologies - Star and Cascade (Daisy Chain)

Ethernet Network Topology

Communication cables for Ethernet logically form a straight-line bus; however, the more devices placed on that bus, the less efficient the network due to increased collisions and the weaker the signal will get due to increased distance. Repeaters can be used to boost signal strength; however a better solution would be placing switches at intermediate positions along the bus. The most common Ethernet topology in use today is the star configuration (see Figure 11), with a hub or switch in the center.

RS-485 Cable Termination

Most RS-485 buses require termination because of fast transitions, high data rates, or long cables. The purpose of the termination is to prevent adverse transmission-line phenomena, such as reflections.

For example, suppose an installation uses 2000 feet of cable. A round trip, then, covers 4000 feet. Using a propagation velocity of $0.66c$ (two thirds the speed of light – contact the cable supplier for this value for your cable), one round trip is completed in approximately 6.2 microseconds. If we assume the reflections will damp out in three round trips up and down the cable length, the signal will stabilize 18.6 microseconds after the leading edge of a bit. At 56K baud (57,600 bits per second) one bit is 17.4 microseconds wide. In this case, the reflections do not damp out before more information is being sent, and corruption of information is a potential problem. Termination will solve this problem as will lowering the baud rate. At 9600 baud, the bit width is 104 microseconds wide, the reflections are damped out much before the center of the bit, and termination is not required. Longer cable length and higher baud rates each push the case for use of termination.

A common mistake is to connect a terminating resistor at each node - a practice that causes trouble on buses that have four or more nodes. The active driver sees the four termination resistors in parallel, a condition that excessively loads the driver. If each of the four nodes connects a 100Ω termination resistor across the bus, the active driver sees a load of 25Ω instead of the intended 50Ω . The problem becomes substantially worse with 32 nodes. If each node includes a 100Ω termination resistor,

the load becomes 3.12Ω .

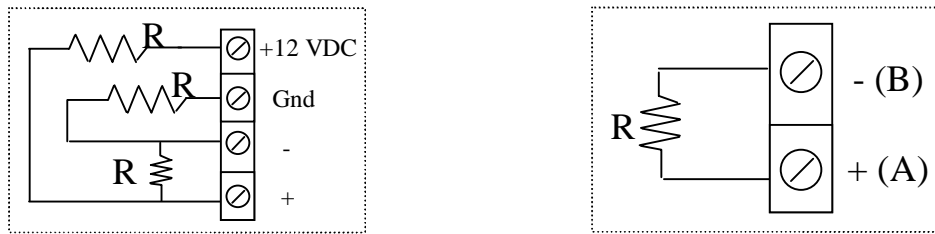

Figure 12: Termination Options - Failsafe (a) and Passive (b)

Bioscrypt recommends that the RS-485 transmission line be terminated at both ends. The recommended termination at the PC end of the line is called Failsafe termination. This terminator (shown in Figure 12A) ensures that there is a proper bias voltage across the receiver inputs. This, in turn, ensures that the receiver is in a known state and puts less of a strain on the driver to provide that bias. This termination is typically built into the RS-232/RS-485 converters and internal PC add-on boards – you should confirm that such a termination exists, but you likely don't have to supply it yourself.

The termination at the opposite end of the transmission line should be parallel (or passive) termination (see Figure 12B). The value of R in Figure 12B is chosen to correspond to a proper parallel termination, R_T , and it is chosen to be slightly larger than the characteristic impedance of the cable, Z_0 . Over-termination tends to be more desirable than under-termination since over-termination has been observed to improve signal quality. R_T is typically chosen to be equal to Z_0 . When over-termination is used R_T is typically chosen to be up to 10% larger than Z_0 . The elimination of reflections permits higher data rates over longer cable lengths.

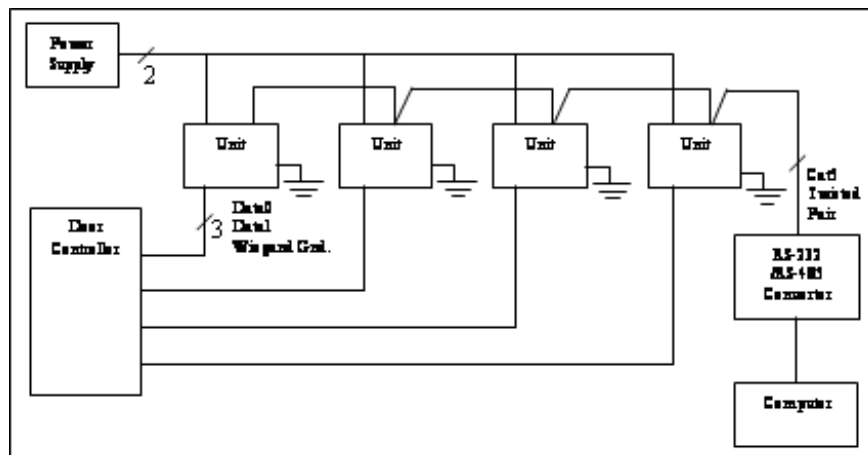

Figure 13: Common Installation Configuration - Power, Earth Ground, Wiegand and RS-485

Extending the RS-485 Specification

Some systems require longer distances or higher numbers of nodes than supported by RS-485. Repeaters are commonly used to overcome these barriers. An RS-485 repeater can be placed in a system to divide the load into multiple segments. Each “refreshed” signal is capable of driving another 4000 feet (1200 meters) of cable and an additional 31 RS-485 unit loads. Using an Ethernet network with switches can also solve this problem. The Veri-Series units represent a single unit load to the transmission line.

For instructions on the configuration and wiring of your RS-485 network, please refer to the “*Configuration for Veri-Series Fingerprint Readers and RS-485/RS-232 Converter*” application note available on the Bioscrypt website.



Figure 14: Wiring Diagram for RS-232/RS-485 Converter

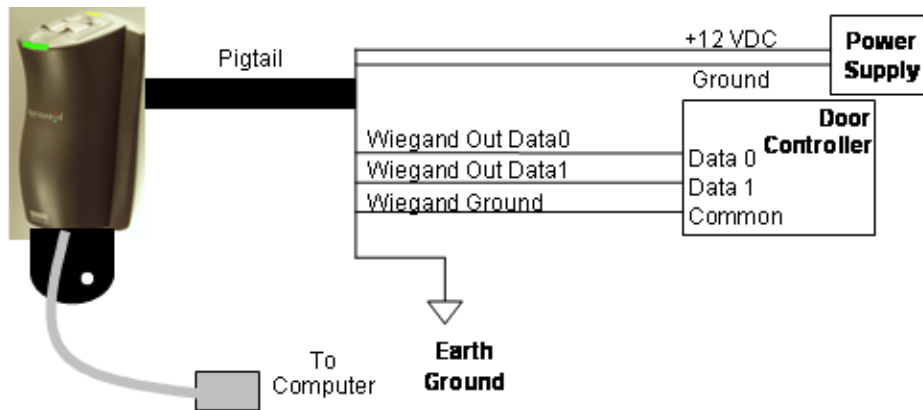

Figure 15: Reader Wiring Schematic

Connecting to the Computer

The Veri-Series units can be connected to the computer either through an RS-232 communications link, an RS-485 link, or via Ethernet (V-Station only).

RS-485 and RS-232 are hardware specifications and software protocol is not specified. It is up to the system designer to define a protocol suitable for the system. Bioscrypt has done this with the Veri-Series reader system. Detailed information on the software protocol can be obtained by contacting Bioscrypt.

RS-232 communications with the Veri-Series unit use RX, TX, and GND connections. The primary communications port is wired through the pigtail in the rear of the unit. There is also an auxiliary RS-232 port accessible from the bottom of the unit.

The RS-485 implementation in the Veri-Series uses a two-wire, half-duplex communication configuration. In RS-485 there can be only one master and all other units are configured as slaves. A master-slave type system has one node that issues commands to each of the "slave" nodes and processes responses. Slave nodes will not typically transmit data without a request from the master node, and do not communicate with each other. Each slave must have a unique address so that it can be addressed independent of other nodes. In the Veri-Series reader system the computer is the master and the readers are each slaves on the network. To connect the computer to the RS-485 transmission line, you must either have a computer with a built-in RS-485 transceiver or use a converter attached to the computer's standard serial port (an RS-232 device). The cable connection includes a differential line (+ and -) and a GND connection.

With the addition of the V-Station products, installations may now connect to these readers via an Ethernet network*. Because Ethernet enabled devices like the V-Station contain unique pre-allocated addresses, there is no need to have a slave/host configuration. Communication collisions are automatically handled by the low-level Ethernet protocol. However, the Veri-Series reader protocol is still used on top of TCP/IP communications protocols. Therefore, a unique IP addresses must be assigned to each V-Station reader, either through the VeriAdmin software/LCD Menu or automatically from a DHCP server on the network**.

In the event that you are connecting a single V-Station directly to the computer's Ethernet adaptor, a crossover cable must be used and the following steps must be taken.

Both the PC and the V-Station must have assigned IP addresses where the beginning numbers match in accordance with the subnet mask used on the PC. For example, if the subnet mask is 255.255.255.0, both the PC and the V-Station must be assigned an IP address of A.B.C.x where A, B, and C are the same for each and x is different.

Additionally, the PC's ARP table may need to be set at the command prompt to resolve the Ethernet MAC address to IP address translation. This last step is not needed on a normal Ethernet network that consists of more than just a single PC-to-V-Station connection. Please see the *Veri-Series Operations Manual* for more information on this topic.

* Ethernet is fully supported in V-Station firmware versions 7.10 and above

** DHCP support may not be available in some versions

System Turn-Up Procedures

System turn-up must follow a step-by-step procedure. Never wire up a system and apply power to it all at once. This can turn a potential success into an immediate disaster.

The following steps should be observed:

1. Do not apply power to any units.
2. Check all wiring and device configuration.
3. Disconnect all units from RS-485 communication line.
4. Check for the correct supply voltage before connecting it to any device.
5. Power up the PC running the VeriAdmin or other software that is designed to work with the Veri- series readers. The RS-232 to RS-485 converter should also be powered up at this time. If communicating to units via Ethernet, be sure the correct cable is connected to the PC NIC card.
6. Configure the PC software.
7. Check for ground fault between the converter and the RS-485 communication line. Find any faults and clear them if they exist.
8. Connect the PC and converter to the RS-485 line.
9. Power up a SLAVE (V-Prox or other reader), but DO NOT connect it to the RS-485 line. Verify that it powers up correctly.
10. Check for ground fault between this unit and the RS-485 communication line. Find any faults and clear them if they exist.
11. Connect this unit to the RS-485 line.
12. Verify that it communicates with the PC software.
13. If there are more SLAVES (V-Prox or other readers), add the subsequent readers by repeating steps 9-12.

Device Configuration Check

Devices must be configured correctly before they can communicate. Common problems include not correctly selecting RS-485 as the Com Port, mismatched baud rates, and incorrect device addresses. Each device sharing the RS-485 line must have a unique address.

Ground Potential Difference Check

Before a device is connected to an RS-485 subsystem, it must be checked for ground fault. An uncorrected ground fault can damage all devices connected to the RS-485 communication line.

To check if there is ground fault for a new unit, follow the steps below:

1. Apply power to all devices already successfully connected to RS-485 line.
2. Power up a new unit, but DO NOT connect it to RS-485 line.
3. Connect the signal ground of the RS-485 line through a 10-k Ω current limiting resistor to the signal ground of the Veri-Series unit. There should NOT be more than 1 volt across the resistor. Otherwise find and clear the fault.
4. Repeat the steps in #3 with each of the RS-485 signal lines (+ and -)
5. Connect the new unit to the RS-485 line only if no ground fault is found.

General Installation Guidelines

Installation Issues:

- Use Category 5 cabling for a RS-485 network
- Use Category 5 shielded cabling for a 10Base-T or 100Base-T Ethernet network and Category 5E cable for Gigabit (1000Base-T) Ethernet and beyond
- Choose one twisted pair of conductors to use for RS-485 differential connection, other conductors should be used for Signal Ground (Pin 12 on pigtail or RS-232/RS-485 GND for V-Station)
- For Ethernet, use a straight-through cable when connecting DTE (V-Station, PC, etc) to DCE (Switch, Hub, Repeater, etc). Use a crossover cable when connecting DTE to DTE or DCE to DCE
- RS-232/RS-485 Converter must support "sense data" to switch from send to receive mode
- If placing a V-Station on a RS-485 network, be sure to set the switch in back to "RS-485 enable"
- Before connecting each unit to the network, do the following:
 - Configure the reader using the auxiliary port (RS-232) and a PC (or directly from the console if a V-Station)
 - Set Network ID to a unique number
 - If a V-Station on Ethernet, set its IP address explicitly
 - Set host port to RS-485
 - Set host port baud rate to 9600 bps
 - Check each unit/cabling for ground fault before connecting to RS-485 network
 - Each unit should have its ESD Shield Ground (Pin 15) connected to Earth Ground (EGND connection on V-Station)
 - Once all units are configured and connected to the RS-485 network, the baud rate can be increased to highest supported rate (some experimentation required)

Network Operation Issues:

- Do not use auxiliary port when RS-485 network is active
- Unit will return a "busy" signal (error -104) if communication cannot be processed due to current processing – usually enroll or verify
- V-Stations communicating over the Ethernet port can only accept one connection at a time
- V-Stations must not be assigned an IP address which is already in use or a conflict will arise, causing communication errors on both devices
- If using Ethernet, an appropriate subnet mask should be set in VeriAdmin to

ensure proper broadcasting capability to all units on the network. For example, a class C network (supporting up to 254 readers) should have a subnet mask of 255.255.255.0. If multiple class C networks are being used within the same network, the subnet mask should resemble the form 255.255.x.0 where x appropriately masks out the bits common to both network addresses.

- Broadcasting to all V-Stations on a network is accomplished in VeriAdmin using UDP, a connectionless datagram protocol. This is not a reliable protocol, and V-Stations will not respond to broadcast communications to verify proper delivery of the message. This should be used as a convenience but not relied upon as a guaranteed communication method. This is especially true if packets are routed, like over the Internet.

Operational Issues:

- V-Prox Cards registered as Command Cards (enroll or delete cards) cannot be utilized as user cards.
- The V-Pass system requires a PC running VeriAdmin or compatible software in order to enroll fingerprints.

Appendix A: Notices

The Veri-Series product line has been tested for compliance with all applicable international standards. The resulting approvals are listed below, and are additionally printed on the labeling located on the rear panel of the product.

The power supply offered by Bioscript is CE and CSA approved and UL listed.

V-Flex	FCC, UL294, CSA, cUL, CE
V-Prox	FCC, UL294, CSA, cUL, CE under R&TTE
V-Pass	FCC, UL294, CSA, cUL, CE
V-Smart	FCC, UL294, CSA, cUL, CE under R&TTE
V-Station	FCC, UL294, CSA, cUL, CE under R&TTE

FCC Information to Users

This equipment has been tested and found to comply with the limits for a Class A digital device, pursuant to Part 15 of the FCC Rules. These limits are designed to provide reasonable protection against harmful interference when the equipment is operated in a commercial environment. This equipment generates, uses, and can radiate radio frequency energy and, if not installed and used in accordance with the instruction manual, may cause harmful interference to radio communications. Operation of this equipment in a residential area is likely to cause harmful interference in which case the user will be required to correct the interference at his own expense.

FCC Class B Digital Device or Peripheral - User's Notice (for all V-Station models only)

This equipment has been tested and found to comply with the limits for a Class B digital device, pursuant to Part 15 of the FCC Rules. These limits are designed to provide reasonable protection against harmful interference in a residential installation. This equipment generates, uses, and can radiate radio frequency energy and, if not installed and used in accordance with the instruction manual, may cause harmful interference to radio communications. However, there is no guarantee that interference will not occur in a particular installation. If this equipment does cause harmful interference to radio or television reception, which can be determined by turning the equipment off and on, the user is encouraged to try to correct the interference by one of more of the following measures:

- Reorient or relocate the receiving antenna
- Increase the separation between the equipment and receiver

- Connect the equipment into an outlet on a circuit different from that to which the receiver is connected
- Consult the dealer or an experienced radio/TV technician for help

CE Information to Users

All Veri-Series devices have the CE mark, for compliance with CISPR22 /EN 55022 requirements. For European Union (EU) countries, V-Prox, V-Smart, and V-Station (models V-Station A, P, V-Station A, G, and V-Station A, H) are compliant with CE under the R&TTE Directive, related to the radio transceivers that are part of their design. More information can be found regarding the CE R&TTE directive online at the European Union web site:

<http://www.europa.eu.int/comm/enterprise/rtte/index.htm>

The V-Prox and V-Smart are compliant with this directive if, and only if, the user installs the Bioscrypt specified R&TTE Installation Kit (Bioscrypt part number 832-00103-00). This filter kit should be included with any V-Prox or V-Smart product if it was shipped to a country within the EU.

The R&TTE Installation Kit consists of two filters: a line filter used to minimize conducted emissions from power supply lead lengths greater than 3 meters and a DB-15 “Pass-Thru” filter used to minimize radiated emissions.

Line Filter:	Manufacturer:	JMK Filters Amhearst, New Hampshire USA, 03031 http://www.JMKFilters.com
	Part Number:	FF-1586-1
Pass-Thru Filter:	Manufacturer:	Spectrum Control Fairview, Pennsylvania USA, 16415 http://www.SpectrumControl.com
	Part Number:	56-605-019

If the filters were not included with the product or if they are desired separately, they may be ordered from Bioscrypt (part number 832-00103-00) or the distributor from which the product was purchased. Please see *Appendix C: R&TTE Kit Filter Installation* for details on proper installation of these filters.

NOTE: The installation of these filters is mandatory for the registered CE mark, and associated R&TTE directive compliance to be valid within the European Union. Failure to do so will render the CE mark and consequent right to operate the equipment null

and void.

Warning to Users

Changes or modifications not expressly approved by Bioscrypt Inc. could void the user’s authority to operate the equipment.



*Within the European Community, use of the 125 kHz band is not harmonized. Therefore this product requires notification to the National Regulatory Body and requires product registration for a particular country. If you intend to move this device within the EU, please contact your distributor first in order to check if this device is approved for use in that particular country.

V-Prox, A, H Information for Users*

The V-Prox, A shall include an embedded HID contact-less proximity reader. This device shall have the following characteristics:

- Transmit Frequency: 125 KHz
- Excite Frequency: 125 KHz

V-Smart, A Information for Users

The V-Smart, A shall include an embedded Gemplus GemEasyLink680SL MIFARE contactless smart card reader. This device shall be a radio-transceiver with the following characteristics:

- Operating Frequency Range: 13.553 – 13.567 MHz
- RF Power Rating: 0.0 Watts
- RF Output Impedance: 50 Ohms

V-Smart, A, H Information for Users

The V-Smart, A, H shall include an embedded HID iCLASS™ Model R10 contactless smart card reader. This device shall be a radio-transceiver with the following characteristics:

- Operating Frequency Range: 13.553 – 13.567 MHz
- RF Power Rating: 0.0 Watts
- RF Output Impedance: 50 Ohms

V-Station, A, G Information for Users

The V-Station, A, G shall include an embedded Gemplus GemEasyLink680SL MIFARE contactless smart card reader. This device shall be a radio-transceiver with the following characteristics:

- Operating Frequency Range: 13.553 – 13.567 MHz
- RF Power Rating: 0.0 Watts
- RF Output Impedance: 50 Ohms

V-Station, A, H Information for Users

The V-Station, A, H shall include an embedded HID iCLASS™ Model R10 contactless smart card reader. This device shall be a radio-transceiver with the following characteristics:

- Operating Frequency Range: 13.553 – 13.567 MHz
- RF Power Rating: 0.0 Watts
- RF Output Impedance: 50 Ohms

V-Station, A, P Information for Users*

The V-Station, A, P shall include an embedded HID contact-less proximity reader. This device shall have the following characteristics:

- Transmit Frequency: 125 KHz
- Excite Frequency: 125 KHz

Appendix B: E.U. Certification Documentation

This appendix contains data related to the Veri-Series product line regarding the test procedures and Declarations of Conformity as required under the R&TTE directive by the European Union for all devices containing radio transmitters. The following Bioscrypt products contain radio transmitters:

<u>Name</u>	<u>Model Number</u>
V-Prox	V-Prox, A
V-Smart MIFARE	V-Smart, A
V-Smart iCLASS	V-Smart, A, H
V-Station Prox	V-Station, A, P
V-Station MIFARE	V-Station, A, G
V-Station iCLASS	V-Station, A, H

Hereby, Bioscrypt declares that the V-Prox, V-Smart/MIFARE, and V-Smart/iCLASS are in compliance with the essential requirements and other relevant provisions of Directive 1999/5/EC.

Restrictions of Use

V-Prox and V-Station Prox

Bioscrypt has notified and gained approval to sell the V-Prox in the following EU countries. **There shall be no restrictions of use for the V-Prox reader within these countries:**

- o Belgium
- o France
- o Germany
- o United Kingdom
- o Ireland
- o Italy
- o Netherlands
- o Portugal
- o Spain
- o Switzerland

V-Smart MIFARE, V-Smart iCLASS, V-Station MIFARE, V-Station iCLASS

Bioscrypt has notified and gained approval to sell the V-Smart in the following EU countries. **There shall be no restrictions of use for the V-Smart reader within these countries.**

- o Austria
- o Belgium
- o Denmark
- o Finland
- o France
- o Germany
- o Greece
- o Ireland
- o Italy
- o Luxemburg
- o Netherlands
- o Portugal
- o Spain
- o Sweden
- o United Kingdom

For latest product approval status and updates, please refer to the Bioscript web page at: <http://www.bioscript.com>.

DECLARATION OF CONFORMITY FOR THE R&TTE DIRECTIVE 1999/5/EC

Manufacturer's Name/Address:	Bioscrypt Inc.
Address:	5450 Explorer Drive, Suite 500 Mississauga, Ontario Canada, L4W 5M1
Contact Person:	Mr. Shiraz Kapadia, Director of Manufacturing Phone #: 905-624-7719 Fax #: 905-624-7742 Email Address: shiraz.kapadia@bioscrypt.com
Equipment Type:	Radio Communications Equipment
Product Name:	V-Prox, A
Model No.:	V-Prox, A, H
RF Output Power:	-6.9 dBuA/m 10 meters
Transmitter Operating Frequency Range:	125 kHz
Emission Designation:	5K7N0N
Duty Cycle:	18.8%
Year of manufacture:	2003
Country Of Manufacture:	Canada
The above product has been tested by UltraTech Engineering Labs Inc., and found to comply with:	European Telecommunications Standards Institute (ETSI) EN 300 330-1 V1.3.1 (2001-06) & EN 300 330-2 V1.1.1 (2001-06); Radio Equipment and Systems; Short Range Devices (SRD); Technical Characteristics and Test Methods for Radio Equipment in the Frequency Range 9 kHz to 25 MHz and Inductive Loop Systems in the Frequency Range 9 kHz to 30 MHz, Parts 1 and 2.
Test Laboratories:	UltraTech EMC Labs Inc. 3000 Bristol Circle Oakville, Ontario, Canada, L6H 6G4

I, the undersigned, hereby declare that the equipment as tested is representative within manufacturing tolerance to units

Manufacturer



Shiraz Kapadia
Director of Manufacturing
Mississauga, ON, Canada
September 9, 2003

Legal Representative in Europe



Neil McDonald
Director of Sales, EMEA
High Wycombe, England
November 25, 2002

DECLARATION OF CONFORMITY FOR THE EMC DIRECTIVE 89/336/EEC

Manufacturer's Name/Address:	Bioscrypt Inc.
Address:	5450 Explorer Drive, Suite 500 Mississauga, Ontario Canada, L4W 5M1
Contact Person:	Mr. Shiraz Kapadia, Director of Manufacturing Phone #: 905-624-7719 Fax #: 905-624-7742 Email Address: shiraz.kapadia@bioscrypt.com
Equipment Type:	Radio Communications Equipment
Product Name:	V-Prox, A
Model No.:	V-Prox, A, H
RF Output Power:	-6.9 dBuA/m 10 meters
Transmitter Operating Frequency Range:	125 kHz
Emission Designation:	5K7N0N
Duty Cycle:	18.8%
Year of manufacture:	2003
Country Of Manufacture:	Canada
The above product has been tested by <i>UltraTech Engineering Labs Inc.</i>, and found to comply with:	European Telecommunications Standards Institute (ETSI) EN 301 489-1 V1.4.1 (2002-04) & EN 301 489-3 V1.4.1 (2002-08) – Electromagnetic Compatibility and Spectrum Matters (ERM); Electromagnetic Compatibility (EMC) Standard for Radio Equipment and Services, Parts 1 and 3.
Test Laboratories:	UltraTech EMC Labs Inc. 3000 Bristol Circle Oakville, Ontario, Canada, L6H 6G4

I, the undersigned, hereby declare that the equipment as tested is representative within manufacturing tolerance to units

Manufacturer



Shiraz Kapadia
Director of Manufacturing
Mississauga, ON, Canada
September 9, 2003

Legal Representative in Europe



Neil McDonald
Director of Sales, EMEA
High Wycombe, England
November 25, 2002

DECLARATION OF CONFORMITY FOR THE LOW VOLTAGE SAFETY DIRECTIVE 73/23/EEC

Manufacturer's Name/Address:	Bioscrypt Inc.
Address:	5450 Explorer Drive, Suite 500 Mississauga, Ontario Canada, L4W 5M1
Contact Person:	Mr. Shiraz Kapadia, Director of Manufacturing Phone #: 905-624-7719 Fax #: 905-624-7742 Email Address: shiraz.kapadia@bioscrypt.com
Equipment Type:	Radio Communications Equipment
Product Name:	V-Prox, A
Model No.:	V-Prox, A, H
RF Output Power:	-6.9 dBuA/m 10 meters
Transmitter Operating Frequency Range:	125 kHz
Emission Designation:	5K7N0N
Duty Cycle:	18.8%
Year of manufacture:	2003
Country Of Manufacture:	Canada
The above product has been tested by <i>UltraTech Engineering Labs Inc.,</i> and found to comply with:	EN 60215:1996 +A1:1996 - Safety Requirements for Radio Transmitting Equipment
Test Laboratories:	UltraTech EMC Labs Inc. 3000 Bristol Circle Oakville, Ontario, Canada, L6H 6G4

I, the undersigned, hereby declare that the equipment as tested is representative within manufacturing tolerance to units

Manufacturer



Shiraz Kapadia
Director of Manufacturing
Mississauga, ON, Canada
September 9, 2003

Legal Representative in Europe



Neil McDonald
Director of Sales, EMEA
High Wycombe, England
November 25, 2002

DECLARATION OF CONFORMITY FOR THE R&TTE DIRECTIVE 1999/5/EC

Manufacturer's Name/Address:	Bioscrypt Inc.
Address:	5450 Explorer Drive, Suite 500 Mississauga, Ontario Canada, L4W 5M1
Contact Person:	Mr. Shiraz Kapadia, Director of Manufacturing Phone #: 905-624-7719 Fax #: 905-624-7742 Email Address: shiraz.kapadia@bioscrypt.com
Equipment Type:	Radio Communications Equipment
Product Name:	V-Smart
Model No.:	V-Smart, A
RF Output Power:	-19.3 dBuA/m 10 meters
Transmitter Operating Frequency Range:	13.553-13.567 MHz
Emission Designation:	3K0D1D
Duty Cycle:	100%
Year of manufacture:	2003
Country Of Manufacture:	Canada
The above product has been tested by UltraTech Engineering Labs Inc., and found to comply with:	European Telecommunications Standards Institute (ETSI) EN 300 330-1 V1.3.1 (2001-06) & EN 300 330-2 V1.1.1 (2001-06); Radio Equipment and Systems; Short Range Devices (SRD); Technical Characteristics and Test Methods for Radio Equipment in the Frequency Range 9 kHz to 25 MHz and Inductive Loop Systems in the Frequency Range 9 kHz to 30 MHz, Parts 1 and 2.
Test Laboratories:	UltraTech EMC Labs Inc. 3000 Bristol Circle Oakville, Ontario, Canada, L6H 6G4

I, the undersigned, hereby declare that the equipment as tested is representative within manufacturing tolerance to units

Manufacturer



Shiraz Kapadia
Director of Manufacturing
Mississauga, ON, Canada
September 9, 2003

Legal Representative in Europe



Neil McDonald
Director of Sales, EMEA
High Wycombe, England
November 25, 2002

DECLARATION OF CONFORMITY FOR THE EMC DIRECTIVE 89/336/EEC

Manufacturer's Name/Address:	Bioscrypt Inc.
Address:	5450 Explorer Drive, Suite 500 Mississauga, Ontario Canada, L4W 5M1
Contact Person:	Mr. Shiraz Kapadia, Director of Manufacturing Phone #: 905-624-7719 Fax #: 905-624-7742 Email Address: shiraz.kapadia@bioscrypt.com
Equipment Type:	Radio Communications Equipment
Product Name:	V-Smart
Model No.:	V-Smart, A
RF Output Power:	-19.3 dBuA/m 10 meters
Transmitter Operating Frequency Range:	13.553-13.567 MHz
Emission Designation:	3K0D1D
Duty Cycle:	100%
Year of manufacture:	2003
Country Of Manufacture:	Canada
The above product has been tested by UltraTech Engineering Labs Inc., and found to comply with:	European Telecommunications Standards Institute (ETSI) EN 301 489-1 V1.4.1 (2002-04) & EN 301 489-3 V1.4.1 (2002-08) – Electromagnetic Compatibility and Spectrum Matters (ERM); Electromagnetic Compatibility (EMC) Standard for Radio Equipment and Services, Parts 1 and 3.
Test Laboratories:	UltraTech EMC Labs Inc. 3000 Bristol Circle Oakville, Ontario, Canada, L6H 6G4

I, the undersigned, hereby declare that the equipment as tested is representative within manufacturing tolerance to units

Manufacturer

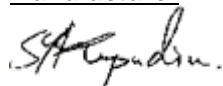

Shiraz Kapadia
Director of Manufacturing
Mississauga, ON, Canada
September 9, 2003

Legal Representative in Europe



Neil McDonald
Director of Sales, EMEA
High Wycombe, England
November 25, 2002

DECLARATION OF CONFORMITY FOR THE LOW VOLTAGE SAFETY DIRECTIVE 73/23/EEC

Manufacturer's Name/Address:	Bioscrypt Inc.
Address:	5450 Explorer Drive, Suite 500 Mississauga, Ontario Canada, L4W 5M1
Contact Person:	Mr. Shiraz Kapadia, Director of Manufacturing Phone #: 905-624-7719 Fax #: 905-624-7742 Email Address: shiraz.kapadia@bioscrypt.com
Equipment Type:	Radio Communications Equipment
Product Name:	V-Smart
Model No.:	V-Smart, A
RF Output Power:	-19.3 dBuA/m 10 meters
Transmitter Operating Frequency Range:	13.553-13.567 MHz
Emission Designation:	3K0D1D
Duty Cycle:	100%
Year of manufacture:	2003
Country Of Manufacture:	Canada
The above product has been tested by UltraTech Engineering Labs Inc., and found to comply with:	EN 60215:1996 +A1:1996 - Safety Requirements for Radio Transmitting Equipment
Test Laboratories:	UltraTech EMC Labs Inc. 3000 Bristol Circle Oakville, Ontario, Canada, L6H 6G4

I, the undersigned, hereby declare that the equipment as tested is representative within manufacturing tolerance to units

Manufacturer



Shiraz Kapadia
Director of Manufacturing
Mississauga, ON, Canada
September 9, 2003

Legal Representative in Europe



Neil McDonald
Director of Sales, EMEA
High Wycombe, England
November 25, 2002

DECLARATION OF CONFORMITY FOR THE R&TTE DIRECTIVE 1999/5/EC

Manufacturer's Name/Address:	Bioscrypt Inc.
Address:	5450 Explorer Drive, Suite 500 Mississauga, Ontario Canada, L4W 5M1
Contact Person:	Mr. Shiraz Kapadia, Director of Manufacturing Phone #: 905-624-7719 Fax #: 905-624-7742 Email Address: shiraz.kapadia@bioscrypt.com
Equipment Type:	Radio Communications Equipment
Product Name:	V-Smart
Model No.:	V-Smart, A, H
RF Output Power:	4.6 dBuA/m 10 meters
Transmitter Operating Frequency Range:	13.553-13.567 MHz
Emission Designation:	3K0D1D
Duty Cycle:	100%
Year of manufacture:	2003
Country Of Manufacture:	Canada
The above product has been tested by UltraTech Engineering Labs Inc., and found to comply with:	European Telecommunications Standards Institute (ETSI) EN 300 330-1 V1.3.1 (2001-06) & EN 300 330-2 V1.1.1 (2001-06); Radio Equipment and Systems; Short Range Devices (SRD); Technical Characteristics and Test Methods for Radio Equipment in the Frequency Range 9 kHz to 25 MHz and Inductive Loop Systems in the Frequency Range 9 kHz to 30 MHz, Parts 1 and 2.
Test Laboratories:	UltraTech EMC Labs Inc. 3000 Bristol Circle Oakville, Ontario, Canada, L6H 6G4

I, the undersigned, hereby declare that the equipment as tested is representative within manufacturing tolerance to units

Manufacturer



Shiraz Kapadia
Director of Manufacturing
Mississauga, ON, Canada
September 9, 2003

Legal Representative in Europe



Neil McDonald
Director of Sales, EMEA
High Wycombe, England
November 25, 2002

DECLARATION OF CONFORMITY FOR THE EMC DIRECTIVE 89/336/EEC

Manufacturer's Name/Address:	Bioscrypt Inc.
Address:	5450 Explorer Drive, Suite 500 Mississauga, Ontario Canada, L4W 5M1
Contact Person:	Mr. Shiraz Kapadia, Director of Manufacturing Phone #: 905-624-7719 Fax #: 905-624-7742 Email Address: shiraz.kapadia@bioscrypt.com
Equipment Type:	Radio Communications Equipment
Product Name:	V-Smart
Model No.:	V-Smart, A, H
RF Output Power:	4.6 dBuA/m 10 meters
Transmitter Operating Frequency Range:	13.553-13.567 MHz
Emission Designation:	3K0D1D
Duty Cycle:	100%
Year of manufacture:	2003
Country Of Manufacture:	Canada
The above product has been tested by UltraTech Engineering Labs Inc., and found to comply with:	European Telecommunications Standards Institute (ETSI) EN 301 489-1 V1.4.1 (2002-04) & EN 301 489-3 V1.4.1 (2002-08) – Electromagnetic Compatibility and Spectrum Matters (ERM); Electromagnetic Compatibility (EMC) Standard for Radio Equipment and Services, Parts 1 and 3.
Test Laboratories:	UltraTech EMC Labs Inc. 3000 Bristol Circle Oakville, Ontario, Canada, L6H 6G4

I, the undersigned, hereby declare that the equipment as tested is representative within manufacturing tolerance to units

Manufacturer

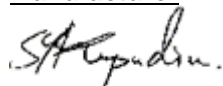

Shiraz Kapadia
Director of Manufacturing
Mississauga, ON, Canada
September 9, 2003

Legal Representative in Europe



Neil McDonald
Director of Sales, EMEA
High Wycombe, England
November 25, 2002

DECLARATION OF CONFORMITY FOR THE LOW VOLTAGE SAFETY DIRECTIVE 73/23/EEC

Manufacturer's Name/Address:	Bioscrypt Inc.
Address:	5450 Explorer Drive, Suite 500 Mississauga, Ontario Canada, L4W 5M1
Contact Person:	Mr. Shiraz Kapadia, Director of Manufacturing Phone #: 905-624-7719 Fax #: 905-624-7742 Email Address: shiraz.kapadia@bioscrypt.com
Equipment Type:	Radio Communications Equipment
Product Name:	V-Smart
Model No.:	V-Smart, A, H
RF Output Power:	4.6 dBuA/m 10 meters
Transmitter Operating Frequency Range:	13.553-13.567 MHz
Emission Designation:	3K0D1D
Duty Cycle:	100%
Year of manufacture:	2003
Country Of Manufacture:	Canada
The above product has been tested by UltraTech Engineering Labs Inc., and found to comply with:	EN 60215:1996 +A1:1996 - Safety Requirements for Radio Transmitting Equipment
Test Laboratories:	UltraTech EMC Labs Inc. 3000 Bristol Circle Oakville, Ontario, Canada, L6H 6G4

I, the undersigned, hereby declare that the equipment as tested is representative within manufacturing tolerance to units

Manufacturer



Shiraz Kapadia
Director of Manufacturing
Mississauga, ON, Canada
September 9, 2003

Legal Representative in Europe



Neil McDonald
Director of Sales, EMEA
High Wycombe, England
November 25, 2002

DECLARATION OF CONFORMITY FOR THE R&TTE DIRECTIVE 1999/5/EC

Manufacturer's Name/Address:	Bioscrypt Inc.
Address:	5450 Explorer Drive, Suite 500 Mississauga, Ontario Canada, L4W 5M1
Contact Person:	Mr. Shiraz Kapadia, Director of Manufacturing Phone #: 905-624-7719 Fax #: 905-624-7742 Email Address: shiraz.kapadia@bioscrypt.com
Equipment Type:	Radio Communications Equipment
Product Name:	V-Station
Model No.:	V-Station, A, P
RF Output Power:	3.2 dBuA/m 10 meters
Transmitter Operating Frequency Range:	120.45– 129.45 kHz
Emission Designation:	4K6N0N
Duty Cycle:	19.9%
Year of manufacture:	2003
Country Of Manufacture:	Canada
The above product has been tested by UltraTech Engineering Labs Inc., and found to comply with:	European Telecommunications Standards Institute (ETSI) EN 300 330-1 V1.3.1 (2001-06) & EN 300 330-2 V1.1.1 (2001-06); Radio Equipment and Systems; Short Range Devices (SRD); Technical Characteristics and Test Methods for Radio Equipment in the Frequency Range 9 kHz to 25 MHz and Inductive Loop Systems in the Frequency Range 9 kHz to 30 MHz, Parts 1 and 2.
Test Laboratories:	UltraTech EMC Labs Inc. 3000 Bristol Circle Oakville, Ontario, Canada, L6H 6G4

I, the undersigned, hereby declare that the equipment as tested is representative within manufacturing tolerance to units

Manufacturer



Shiraz Kapadia
Director of Manufacturing
Mississauga, ON, Canada
September 9, 2003

Legal Representative in Europe



Neil McDonald
Director of Sales, EMEA
High Wycombe, England
January 6, 2003

DECLARATION OF CONFORMITY FOR THE EMC DIRECTIVE 89/336/EEC

Manufacturer's Name/Address:	Bioscrypt Inc.
Address:	5450 Explorer Drive, Suite 500 Mississauga, Ontario Canada, L4W 5M1
Contact Person:	Mr. Shiraz Kapadia, Director of Manufacturing Phone #: 905-624-7719 Fax #: 905-624-7742 Email Address: shiraz.kapadia@bioscrypt.com
Equipment Type:	Radio Communications Equipment
Product Name:	V-Station
Model No.:	V-Station, A, P
RF Output Power:	3.2 dBuA/m 10 meters
Transmitter Operating Frequency Range:	120.45– 129.45 kHz
Emission Designation:	4K6N0N
Duty Cycle:	19.9%
Year of manufacture:	2003
Country Of Manufacture:	Canada
The above product has been tested by UltraTech Engineering Labs Inc., and found to comply with:	European Telecommunications Standards Institute (ETSI) EN 301 489-1 V1.4.1 (2002-04) & EN 301 489-3 V1.4.1 (2002-08) – Electromagnetic Compatibility and Spectrum Matters (ERM); Electromagnetic Compatibility (EMC) Standard for Radio Equipment and Services, Parts 1 and 3.
Test Laboratories:	UltraTech EMC Labs Inc. 3000 Bristol Circle Oakville, Ontario, Canada, L6H 6G4

I, the undersigned, hereby declare that the equipment as tested is representative within manufacturing tolerance to units

Manufacturer

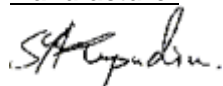

Shiraz Kapadia
Director of Manufacturing
Mississauga, ON, Canada
September 9, 2003

Legal Representative in Europe



Neil McDonald
Director of Sales, EMEA
High Wycombe, England
January 6, 2003

DECLARATION OF CONFORMITY FOR THE LOW VOLTAGE SAFETY DIRECTIVE 73/23/EEC

Manufacturer's Name/Address:	Bioscrypt Inc.
Address:	5450 Explorer Drive, Suite 500 Mississauga, Ontario Canada, L4W 5M1
Contact Person:	Mr. Shiraz Kapadia, Director of Manufacturing Phone #: 905-624-7719 Fax #: 905-624-7742 Email Address: shiraz.kapadia@bioscrypt.com
Equipment Type:	Radio Communications Equipment
Product Name:	V-Station
Model No.:	V-Station, A, P
RF Output Power:	3.2 dBuA/m 10 meters
Transmitter Operating Frequency Range:	120.45– 129.45 kHz
Emission Designation:	4K6N0N
Duty Cycle:	19.9%
Year of manufacture:	2003
Country Of Manufacture:	Canada
The above product has been tested by UltraTech Engineering Labs Inc., and found to comply with:	EN 60215:1996 +A1:1996 - Safety Requirements for Radio Transmitting Equipment
Test Laboratories:	UltraTech EMC Labs Inc. 3000 Bristol Circle Oakville, Ontario, Canada, L6H 6G4

I, the undersigned, hereby declare that the equipment as tested is representative within manufacturing tolerance to units

Manufacturer



Shiraz Kapadia
Director of Manufacturing
Mississauga, ON, Canada
September 9, 2003

Legal Representative in Europe



Neil McDonald
Director of Sales, EMEA
High Wycombe, England
January 6, 2003

DECLARATION OF CONFORMITY FOR THE R&TTE DIRECTIVE 1999/5/EC

Manufacturer's Name/Address:	Bioscrypt Inc.
Address:	5450 Explorer Drive, Suite 500 Mississauga, Ontario Canada, L4W 5M1
Contact Person:	Mr. Shiraz Kapadia, Director of Manufacturing Phone #: 905-624-7719 Fax #: 905-624-7742 Email Address: shiraz.kapadia@bioscrypt.com
Equipment Type:	Radio Communications Equipment
Product Name:	V-Station
Model No.:	V-Station, A,G
RF Output Power:	-10.6 dBuA/m 10 meters
Transmitter Operating Frequency Range:	13.553-13.567 MHz
Emission Designation:	421K3D1D
Duty Cycle:	100%
Year of manufacture:	2003
Country Of Manufacture:	Canada
The above product has been tested by UltraTech Engineering Labs Inc., and found to comply with:	European Telecommunications Standards Institute (ETSI) EN 300 330-1 V1.3.1 (2001-06) & EN 300 330-2 V1.1.1 (2001-06) Radio Equipment and Systems; Short Range Devices (SRD); Technical Characteristics and Test Methods for Radio Equipment in the Frequency Range 9 kHz to 25 MHz and Inductive Loop Systems in the Frequency Range 9 kHz to 30 MHz, Parts 1 and 2.
Test Laboratories:	UltraTech EMC Labs Inc. 3000 Bristol Circle Oakville, Ontario, Canada, L6H 6G4

I, the undersigned, hereby declare that the equipment as tested is representative within manufacturing tolerance to units

Manufacturer



Shiraz Kapadia
Director of Manufacturing
Mississauga, ON, Canada
September 9, 2003

Legal Representative in Europe



Neil McDonald
Director of Sales, EMEA
High Wycombe, England
January 6, 2003

DECLARATION OF CONFORMITY FOR THE EMC DIRECTIVE 89/336/EEC

Manufacturer's Name/Address:	Bioscrypt Inc.
Address:	5450 Explorer Drive, Suite 500 Mississauga, Ontario Canada, L4W 5M1
Contact Person:	Mr. Shiraz Kapadia, Director of Manufacturing Phone #: 905-624-7719 Fax #: 905-624-7742 Email Address: shiraz.kapadia@bioscrypt.com
Equipment Type:	Radio Communications Equipment
Product Name:	V-Station
Model No.:	V-Station, A, G
RF Output Power:	-10.6 dBuA/m 10 meters
Transmitter Operating Frequency Range:	13.553-13.567 MHz
Emission Designation:	421K3D1D
Duty Cycle:	100%
Year of manufacture:	2003
Country Of Manufacture:	Canada
The above product has been tested by UltraTech Engineering Labs Inc., and found to comply with:	European Telecommunications Standards Institute (ETSI) EN 301 489-1 V1.4.1 (2002-04) & EN 301 489-3 V1.4.1 (2002-08) – Electromagnetic Compatibility and Spectrum Matters (ERM); Electromagnetic Compatibility (EMC) Standard for Radio Equipment and Services, Parts 1 and 3.
Test Laboratories:	UltraTech EMC Labs Inc. 3000 Bristol Circle Oakville, Ontario, Canada, L6H 6G4

I, the undersigned, hereby declare that the equipment as tested is representative within manufacturing tolerance to units

Manufacturer

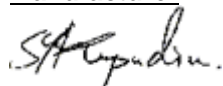

Shiraz Kapadia
Director of Manufacturing
Mississauga, ON, Canada
September 9, 2003

Legal Representative in Europe



Neil McDonald
Director of Sales, EMEA
High Wycombe, England
January 6, 2003

DECLARATION OF CONFORMITY FOR THE LOW VOLTAGE SAFETY DIRECTIVE 73/23/EEC

Manufacturer's Name/Address:	Bioscrypt Inc.
Address:	5450 Explorer Drive, Suite 500 Mississauga, Ontario Canada, L4W 5M1
Contact Person:	Mr. Shiraz Kapadia, Director of Manufacturing Phone #: 905-624-7719 Fax #: 905-624-7742 Email Address: shiraz.kapadia@bioscrypt.com
Equipment Type:	Radio Communications Equipment
Product Name:	V-Station
Model No.:	V-Station, A, G
RF Output Power:	-10.6 dBuA/m 10 meters
Transmitter Operating Frequency Range:	13.553-13.567 MHz
Emission Designation:	421K3D1D
Duty Cycle:	100%
Year of manufacture:	2003
Country Of Manufacture:	Canada
The above product has been tested by UltraTech Engineering Labs Inc., and found to comply with:	EN 60215:1996 +A1:1996 - Safety Requirements for Radio Transmitting Equipment
Test Laboratories:	UltraTech EMC Labs Inc. 3000 Bristol Circle Oakville, Ontario, Canada, L6H 6G4

I, the undersigned, hereby declare that the equipment as tested is representative within manufacturing tolerance to units

Manufacturer

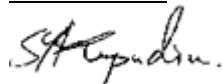

Shiraz Kapadia
Director of Manufacturing
Mississauga, ON, Canada
September 9, 2003

Legal Representative in Europe



Neil McDonald
Director of Sales, EMEA
High Wycombe, England
January 6, 2003

DECLARATION OF CONFORMITY FOR THE R&TTE DIRECTIVE 1999/5/EC

Manufacturer's Name/Address:	Bioscrypt Inc.
Address:	5450 Explorer Drive, Suite 500 Mississauga, Ontario Canada, L4W 5M1
Contact Person:	Mr. Shiraz Kapadia, Director of Manufacturing Phone #: 905-624-7719 Fax #: 905-624-7742 Email Address: shiraz.kapadia@bioscrypt.com
Equipment Type:	Radio Communications Equipment
Product Name:	V-Station
Model No.:	V-Station, A, H
RF Output Power:	-6.4 dBuA/m 10 meters
Transmitter Operating Frequency Range:	13.553-13.567 MHz
Emission Designation:	20K0D1D
Duty Cycle:	100%
Year of manufacture:	2003
Country Of Manufacture:	Canada
The above product has been tested by UltraTech Engineering Labs Inc., and found to comply with:	European Telecommunications Standards Institute (ETSI) EN 300 330-1 V1.3.1 (2001-06) & EN 300 330-2 V1.1.1 (2001-06); Radio Equipment and Systems; Short Range Devices (SRD); Technical Characteristics and Test Methods for Radio Equipment in the Frequency Range 9 kHz to 25 MHz and Inductive Loop Systems in the Frequency Range 9 kHz to 30 MHz, Parts 1 and 2.
Test Laboratories:	UltraTech EMC Labs Inc. 3000 Bristol Circle Oakville, Ontario, Canada, L6H 6G4

I, the undersigned, hereby declare that the equipment as tested is representative within manufacturing tolerance to units

Manufacturer



Shiraz Kapadia
Director of Manufacturing
Mississauga, ON, Canada
September 9, 2003

Legal Representative in Europe



Neil McDonald
Director of Sales, EMEA
High Wycombe, England
January 6, 2003

DECLARATION OF CONFORMITY FOR THE EMC DIRECTIVE 89/336/EEC

Manufacturer's Name/Address:	Bioscrypt Inc.
Address:	5450 Explorer Drive, Suite 500 Mississauga, Ontario Canada, L4W 5M1
Contact Person:	Mr. Shiraz Kapadia, Director of Manufacturing Phone #: 905-624-7719 Fax #: 905-624-7742 Email Address: shiraz.kapadia@bioscrypt.com
Equipment Type:	Radio Communications Equipment
Product Name:	V-Station
Model No.:	V-Station, A, H
RF Output Power:	-6.4 dBuA/m 10 meters
Transmitter Operating Frequency Range:	13.553-13.567 MHz
Emission Designation:	20K0D1D
Duty Cycle:	100%
Year of manufacture:	2003
Country Of Manufacture:	Canada
The above product has been tested by UltraTech Engineering Labs Inc., and found to comply with:	European Telecommunications Standards Institute (ETSI) EN 301 489-1 V1.4.1 (2002-04) & EN 301 489-3 V1.4.1 (2002-08) – Electromagnetic Compatibility and Spectrum Matters (ERM); Electromagnetic Compatibility (EMC) Standard for Radio Equipment and Services, Parts 1 and 3.
Test Laboratories:	UltraTech EMC Labs Inc. 3000 Bristol Circle Oakville, Ontario, Canada, L6H 6G4

I, the undersigned, hereby declare that the equipment as tested is representative within manufacturing tolerance to units

Manufacturer

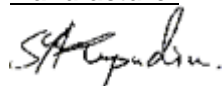

Shiraz Kapadia
Director of Manufacturing
Mississauga, ON, Canada
September 9, 2003

Legal Representative in Europe



Neil McDonald
Director of Sales, EMEA
High Wycombe, England
January 6, 2003

DECLARATION OF CONFORMITY FOR THE LOW VOLTAGE SAFETY DIRECTIVE 73/23/EEC

Manufacturer's Name/Address:	Bioscrypt Inc.
Address:	5450 Explorer Drive, Suite 500 Mississauga, Ontario Canada, L4W 5M1
Contact Person:	Mr. Shiraz Kapadia, Director of Manufacturing Phone #: 905-624-7719 Fax #: 905-624-7742 Email Address: shiraz.kapadia@bioscrypt.com
Equipment Type:	Radio Communications Equipment
Product Name:	V-Station
Model No.:	V-Station, A, H
RF Output Power:	-6.4 dBuA/m 10 meters
Transmitter Operating Frequency Range:	13.553-13.567 MHz
Emission Designation:	20K0D1D
Duty Cycle:	100%
Year of manufacture:	2003
Country Of Manufacture:	Canada
The above product has been tested by UltraTech Engineering Labs Inc., and found to comply with:	EN 60215:1996 +A1:1996 - Safety Requirements for Radio Transmitting Equipment
Test Laboratories:	UltraTech EMC Labs Inc. 3000 Bristol Circle Oakville, Ontario, Canada, L6H 6G4

I, the undersigned, hereby declare that the equipment as tested is representative within manufacturing tolerance to units

Manufacturer



Shiraz Kapadia
Director of Manufacturing
Mississauga, ON, Canada
September 9, 2003

Legal Representative in Europe



Neil McDonald
Director of Sales, EMEA
High Wycombe, England
January 6, 2003

Appendix C: R&TTE Kit Filter Installation

The following two sections describe the proper procedures for installing the R&TTE Installation Kit filters, which are required in certain European countries for full CE compliance. These kits are required only for the V-Prox and V-Smart products and are not required for any other Bioscript product. More information can be found regarding the CE R&TTE directive online at the European Union web site: <http://www.europa.eu.int/comm/enterprise/rtte/index.htm>.

R&TTE Wiring Instructions for the V-Prox, A, H

In order to comply with the conducted emissions requirements of the European Union (EU) directive EN 55022 for DC power input/output ports, an additional line filter is needed for installations where power supply cables are greater than 3 meters in length. The required filter is manufactured by JMK Filters (Amhearst, New Hampshire, USA), Part No. FF-1586-1, and is shipped as part of the installation kit. Please note the orientation of the filter: the end labeled "LOAD" is to be connected to the V-Prox device, the end labeled "LINE" is to be connected to the system power supply.

In order to comply with the radiated emissions requirements of the European Union R&TTE directive CISPR22, a high-density DB-15 "pass-thru" filter is required. The required filter is manufactured by Spectrum Control (Fairview, Pennsylvania, USA), Part No. 56-605-019, and is shipped as part of the installation kit. Please note that it is necessary to rotate the filter to pass through the aperture of the wall plate or mullion. It is easiest if the filter is first connected to the pigtail wiring harness supplied. The cable assembly (and connected filter) is now rotated 90 degrees to allow passage through the aperture of the wall plate. The V-Prox device should next be connected to the cable assembly, and then pushed back through the aperture until the wall plate is between the two mounting flanges of the filter. The device may now be rotated back 90 degrees to the upright position and lowered onto the mounting hooks of the wall plate.

Please see Figure 16 for wiring details.

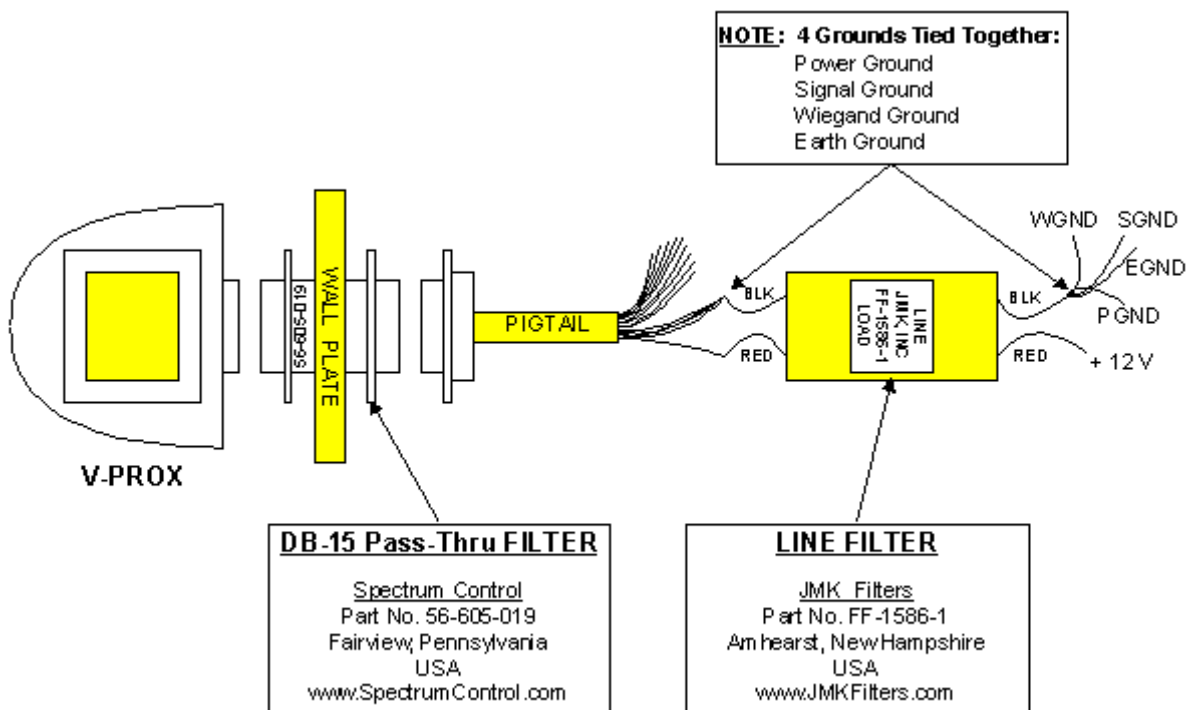

Figure 16: V-Prox R&TTE Installation Kit Wiring Diagram

R&TTE Wiring Instructions for the V-Smart, A and V-Smart, A, H

In order to comply with the conducted emissions requirements of the European Community directive EN 55022 for DC power input/output ports, an additional line filter is needed for installations where power supply cables are greater than 3 meters in length. The required filter is manufactured by JMK Filters (Amhearst, New Hampshire, USA), Part No. FF-1586-1, and is shipped as part of the installation kit. Please note the orientation of the filter: the end labeled "LOAD" is to be connected to the V-Smart device, the end labeled "LINE" is to be connected to the system power supply.

In order to comply with the radiated emissions requirements of the European Community R&TTE directive CISPR22, a high-density DB-15 "pass-thru" filter is required. The required filter is manufactured by Spectrum Control (Fairview, Pennsylvania, USA), Part No. 56-605-019, and is shipped as part of the installation kit. Please note that it is necessary to rotate the filter to pass through the aperture of the wall plate or mullion. It is easiest if the filter is first connected to the pigtail wiring harness supplied. The cable assembly (and connected filter) is now rotated 90 degrees to allow passage through the aperture of the wall plate. The V-Smart device should next be connected to the cable assembly, and then pushed back through the aperture until the wall plate is between the two mounting flanges of the filter. The device may now be rotated back 90 degrees to the upright position and lowered onto the mounting

hooks of the wall plate.

Please see Figure 17 for wiring details.

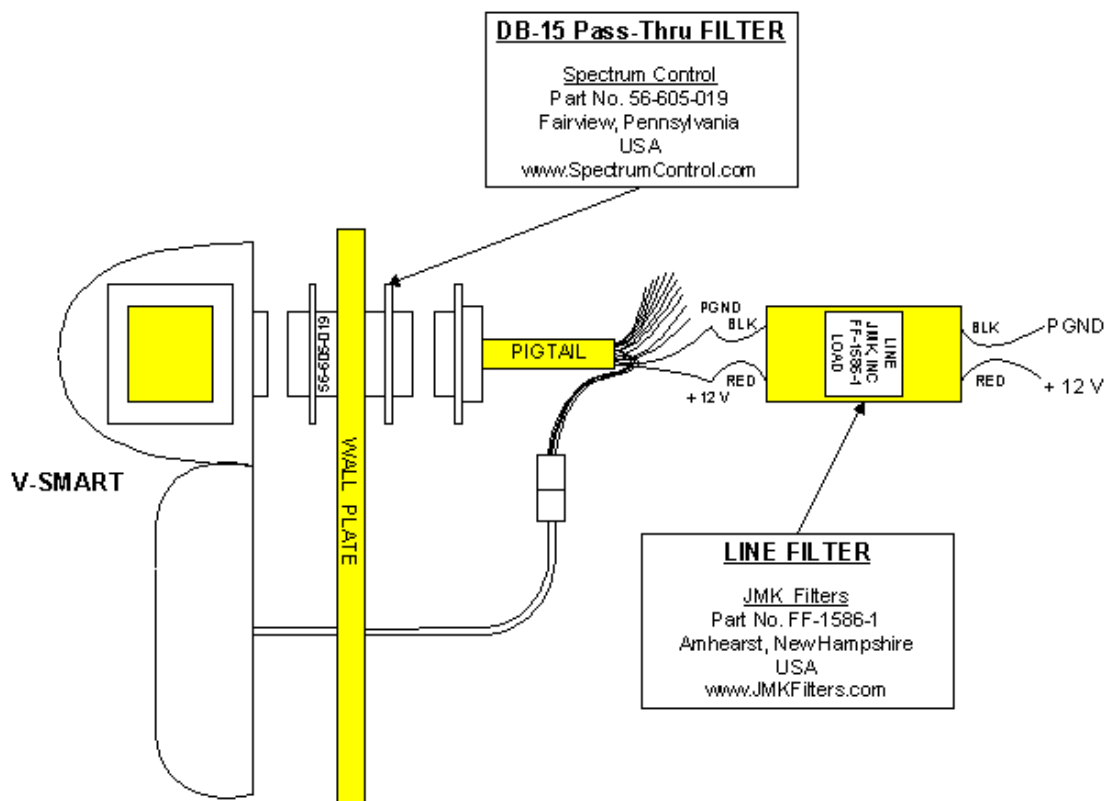

Figure 17: V-Smart R&TTE Installation Kit Wiring Diagram

References

B & B Electronics offers an Application Note on RS-485 devices, system configuration, and termination.

B & B Electronics
 707 Dayton Road
 P.O. Box 1040
 Ottawa, IL 61350
 (815) 433-5100
<http://www.bb-elec.com>

Robust Data Comm provides services and a vast amount of information at their WWW site.

Robust Data Comm, Inc.
 St. Paul, MN 55112
 (612) 628-0533
<http://www.robustdc.com>

The Specification is formally named TIA/EIA-485-A and can be purchased from Global Engineering Documents:

<http://global.ihs.com>

National Semiconductor provides a number of Application Notes:

<http://www.national.com/an/AN/>

Belden Wire and Cable Company offers a variety of cables suitable for RS-485 use and has a number of technical papers:

<http://www.belden.com>

Alpha Wire Company offers a variety of cables suitable for RS-485 use and has a number of technical papers:

<http://www.alphawire.com>

Cisco Systems, Inc., provides a comprehensive guide to Ethernet 802.x standards and implementation issues:

http://www.cisco.com/univercd/cc/td/doc/cisintwk/ito_doc/ethernet.htm

Charles Spurgeon provides an excellent online Ethernet resource:

<http://www.ethermanage.com/ethernet/ethernet.html>

The CE R&TTE directive is outlined on the EU website at:

<http://www.europa.eu.int/comm/enterprise/rtte/index.htm>

Bioscript Contact Information

Technical Support Contact Information:

Telephone: 866.304.7180 (toll free)
818.304.7180 (direct)

Fax: 818.304.7187

Email: support@bioscript.com

Web: <http://www.bioscript.com>

Hours: 5:30A – 5:00P PST (Monday – Friday)

Address: Bioscript Inc
Technical Support / RMA Dept
5805 Sepulveda Blvd, Suite 750
Van Nuys, CA, 91411

Corporate & Canadian Office
5450 Explorer Drive, Suite 500
Mississauga, ON, Canada L4W 5M1
T 905 624 7700
F 905 624 7742
www.bioscript.com

U.S. Office
5805 Sepulveda Blvd., Suite 750
Van Nuys, CA 91411
T 818 304 7150
F 818 461-0843

U.K. Office
35 Jackson Court, Hazlemere
High Wycombe, Buckinghamshire
England HP15 7TZ
T +44 (0) 1494 814 404
F +44 (0) 1494 815 513