

Excel 10

W7763C,D,E CHILLED CEILING CONTROLLERS



INSTALLATION INSTRUCTIONS

BEFORE INSTALLATION

The Excel 10 Chilled Ceiling Controller is available in the following three models:

1. W7763C—with integral setpoint adjustment, temperature sensor, and bypass push-button.
2. W7763D—with integral setpoint adjustment only.
3. W7763E—no integral setpoint adjustment, sensor, or push-button.

The models all have similar housings and mounting procedures.

IMPORTANT

It is recommended that devices be kept at room temperature for at least 24 hours before applying power to allow any condensation resulting from low shipping/storage temperatures to evaporate.

INSTALLATION

W7763 Chilled Ceiling Controllers can be mounted on a panel or wall or onto a standard 60-mm wall outlet box using No. 6 (3.5-mm) screws. See Fig. 1 for outside dimensions and Fig. 2 for subbase mounting dimensions.

The controller can be mounted in any orientation desired; however, for thermal reasons, W7763C Controllers must not be mounted on a ceiling.

Wiring

All wiring must comply with applicable electrical codes and ordinances. Refer to job or manufacturers' drawings for details.

Power

Input power provided must be 24 Vac ($\pm 20\%$), 50 or 60 Hz. For US installation, power must come from an energy-limited Class II Power Source (transformers must not exceed 100 VA). More than one W7763 Controller can be powered by a single transformer.



CAUTION

Turn off power prior to connecting to or removing connections from any terminals to avoid electrical shock or equipment damage.

Use the heaviest gauge wire available, up to 14 AWG (2.5 mm^2) with a minimum of 18 AWG (1.0 mm^2) for all power wiring.

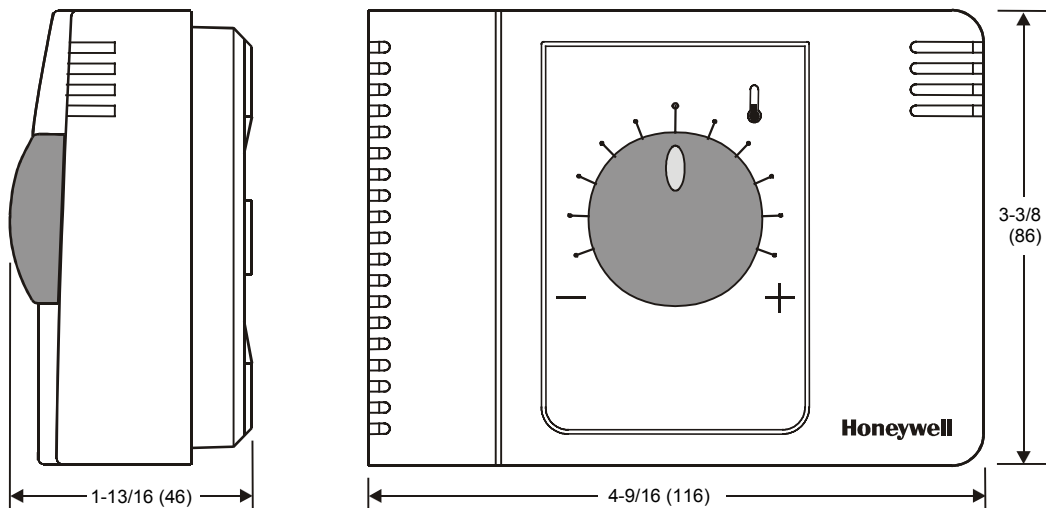

Fig. 1. Excel 10 Chilled Ceiling Controller outside dimensions in in. (mm).



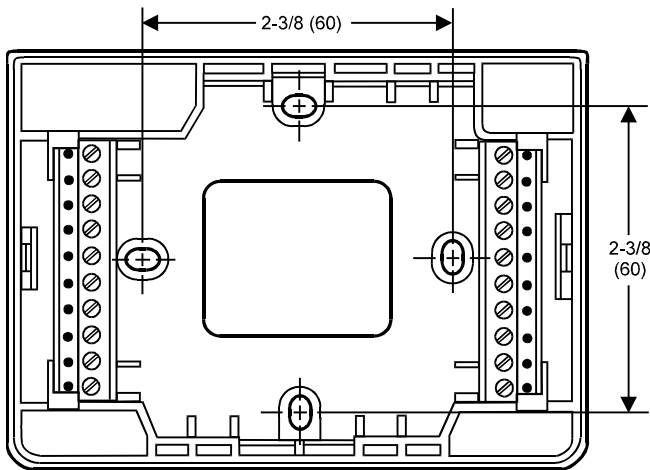

Fig. 2. Subbase mounting dimensions.

IMPORTANT (US only)

If the W7763 Controller is used on **UL 1995 Heating and Cooling Equipment** and the transformer primary power is more than 150 Vac, connect the transformer's secondary to earth ground. For these applications, only one Excel 10 controller can be powered by each transformer.

Communications

Wire the controller's LONWORKS® network using level IV 22 AWG (Belden part number 9D220150) or plenum-rated level IV 22 AWG (Belden part number 9H2201504) nonshielded, twisted pair, solid conductor wire. When possible, use Honeywell AK3781, AK3782, AK3791, or AK3792 cable (US part numbers). See *E-Bus* (LONWORKS® network) *Wiring Practices*, form number 74-2865, for more information including maximum lengths.

Pull the cable to each controller on the LONWORKS® network and connect to terminals 19 and 20.

The W7763 Chilled Ceiling Controller utilizes a free topology transceiver (FTT10A) Link Power compatible LONWORKS® network that allows daisy-chain, loop, and star network configurations or any combination thereof. Depending upon the LONWORKS® network configuration used, one or two termination modules, part number 209541B, may be required. Different connections to the termination module are necessary, depending upon whether it is used in a singly- or doubly-terminated network configuration. See Excel 10 FTT/LPT 209541B Termination Module Installation Instructions, form 95-7554.

NOTES:

- The LONWORKS® network is insensitive to polarity, eliminating installation errors due to miswiring.
- Do not bundle output wires with sensor, digital input or communications bus wires. Maintain a minimum 3 in. (76 mm) separation between LONWORKS® network and Triac output and power supply wiring.
- During installations, try to avoid areas of high electromagnetic noise (EMI).
- Chilled Ceiling Controllers have a 3.5-mm LONWORKS® network jack for easy network access.
- For more information see *E-Bus* (LONWORKS® network) *Wiring Guidelines*, form number 74-2865.

Wall Modules

A variety of Excel 10 wall modules can be used with W7763 Chilled Ceiling Controllers. See T7460 Wall Modules Installation Instructions, form number 95-7610; T7560 Digital Wall Module Installation Instructions, form number 95-7620; and T7770 Wall Modules Installation Instructions, form number 95-7538 for installation details.

NOTE: Wall Modules with fan speed switches must not be used with W7763 Chilled Ceiling Controllers.

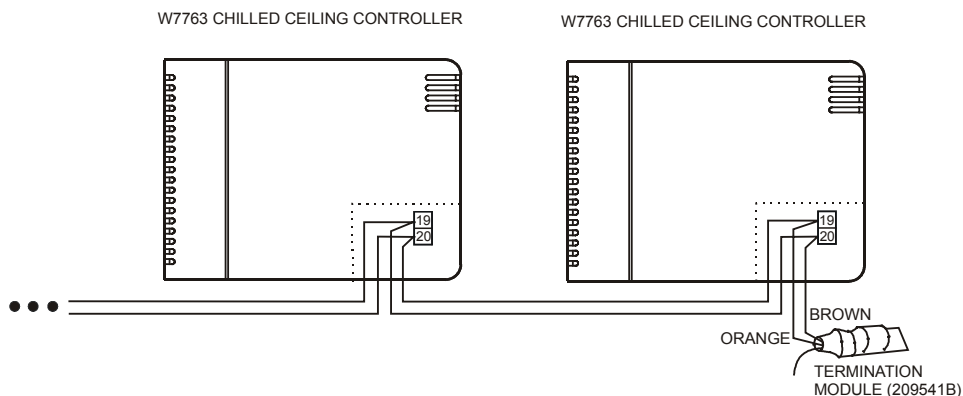

Fig. 3. Termination module connection (daisy-chain network configuration).

Wiring Details

Connections to the Chilled Ceiling controllers are made at two internal terminal blocks accessible beneath the front cover. No tools are required to remove the front cover. Simply pull away from the subbase as shown in Fig. 4.

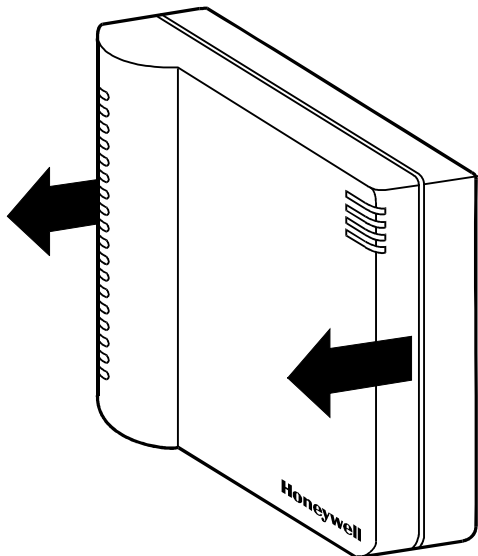

Fig. 4. Terminal cover removal.

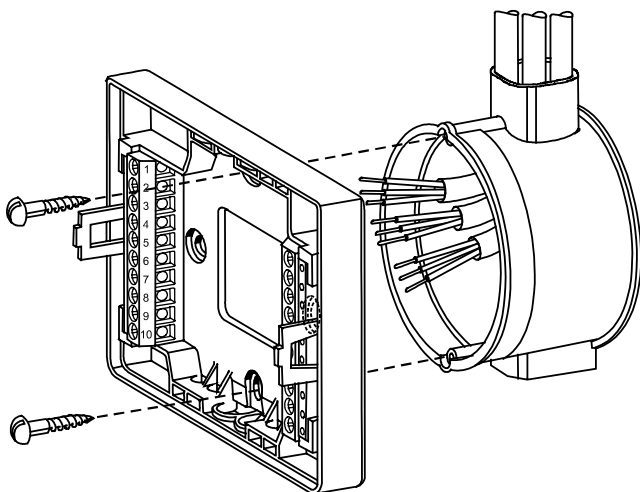

Fig. 5. Mounting on wall outlet box.

Use a minimum wire size of 20 AWG (0.5 mm²) for all input / output connections. The maximum length of all input / output cables and wall module interface cables is 65 ft (20 m). Maintain 3 in. (76 mm) minimum spacing between signal lines 1-10 and Triac output and power supply wiring.

Fig. 8 illustrates the terminal assignments of the controllers. Table 1 lists Triac output assignments for various actuator types. Refer to job drawings for specific wiring diagrams.

IMPORTANT

Screw type terminal blocks are designed to accept no more than one 14 AWG (2.5 mm²) conductor. Multiple wires that are 14 AWG (2.5 mm²) can be connected with a wire nut. Include a pigtail with this wire group and attach the pigtail to the individual terminal block.

Wire to the terminal blocks as follows:

1. Strip 1/2 in. (13 mm) insulation from the conductor.
2. Insert the wire in the required terminal location and tighten the screw to complete the termination. Insure that the wire entering the terminal block does not extend above the numbered face of the terminal block to avoid contact between the wires and the printed circuit board on the underside of the front cover (see Fig. 6.)

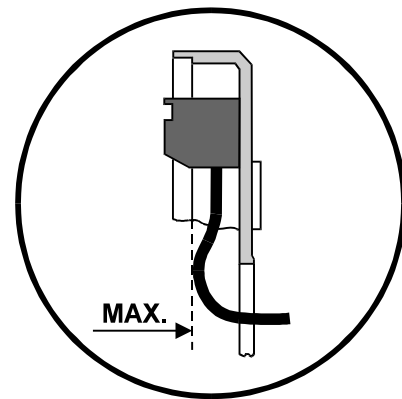
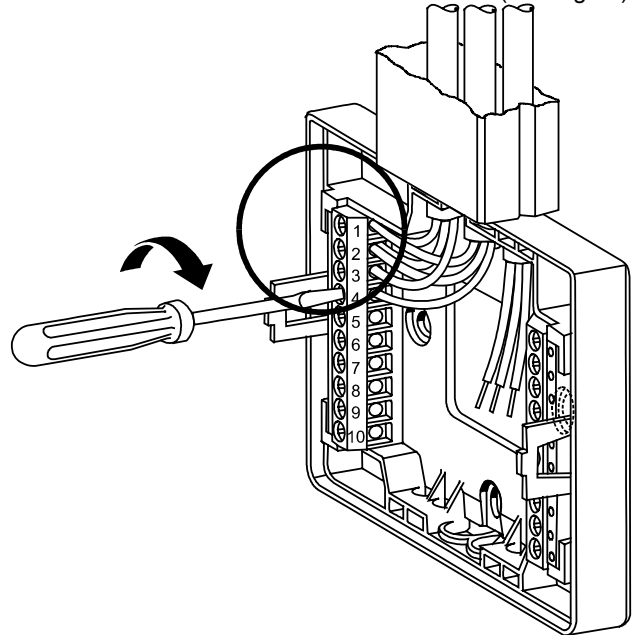

Fig. 6. Terminal block connections.

IMPORTANT

When two or more wires are to be attached to the same terminal, be sure to twist them together. Deviations from this rule can result in improper electrical contact. See Fig. 7. Local wiring codes may take precedence over this recommendation.

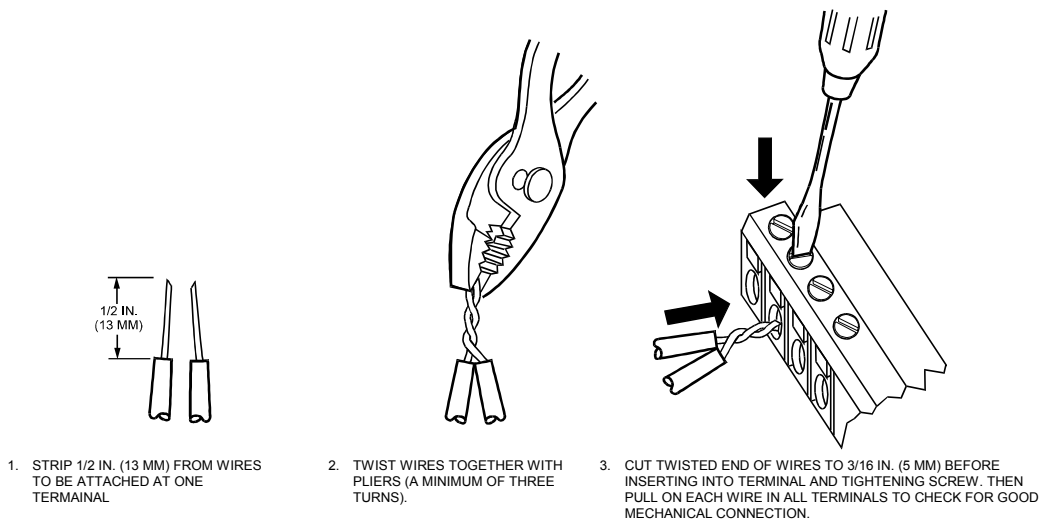

Fig. 7. Attaching two or more wires at terminal blocks.

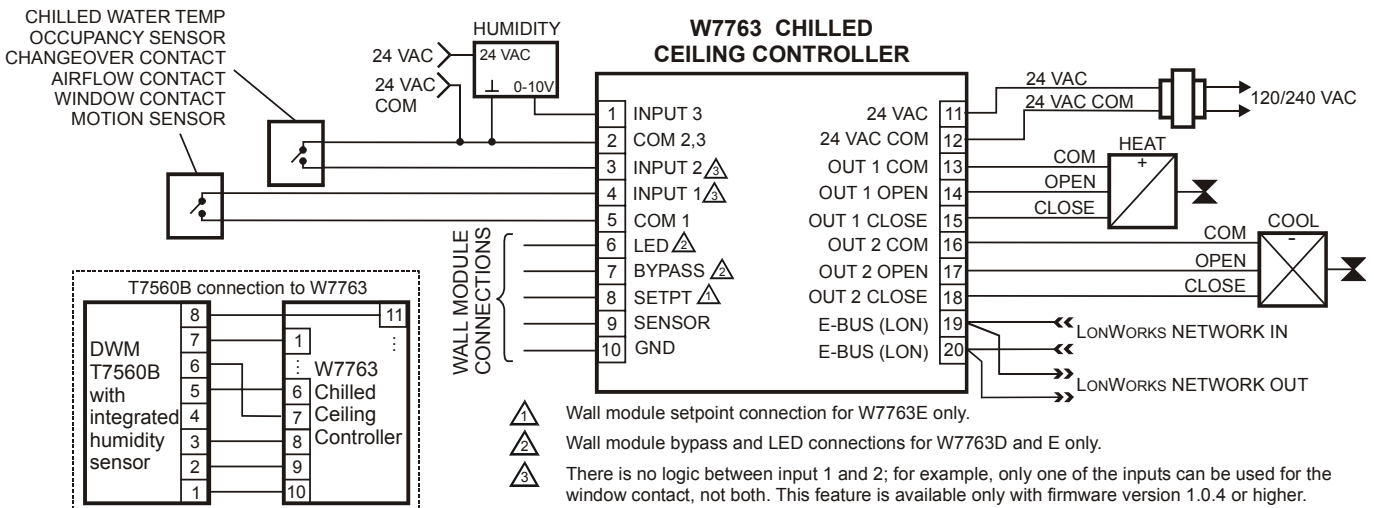

Fig. 8. Chilled Ceiling Controller terminal assignments.

Table 1. Output assignments for various actuator types.

| Output type | Out 1 Terminal | | | Out 2 Terminal | | |
|-------------|----------------|---------|---------|----------------|---------|---------|
| | 13 | 14 | 15 | 16 | 17 | 18 |
| Floating | 24 Vac | open | close | 24 Vac | open | close |
| 1-stage | 24 Vac | on/off | — | 24 Vac | on/off | — |
| 2-stage | 24 Vac | stage 1 | stage 2 | 24 Vac | stage 1 | stage 2 |
| 3-stage | 24 Vac | stage 1 | stage 2 | 24 Vac | stage 1 | stage 2 |
| | | stage 3 | | | stage 3 | |
| PWM | 24 Vac | PWM | — | 24 Vac | PWM | — |
| Thermal | 24 Vac | on/off | — | 24 Vac | on/off | — |

Honeywell

Home and Building Control
Honeywell Inc.
Honeywell Plaza
P.O. Box 524
Minneapolis, MN 55408-0524
USA
http://www.honeywell.com

Home and Building Control
Honeywell Limited-Honeywell Limitee
155 Gordon Baker Road
North York, Ontario
M2H 3N7
Canada
http://www.honeywell.ca

Home and Building Control Products
Honeywell AG
Böblinger Straße 17
D-71101 Schönaich
Germany
http://europe.hbc.honeywell.com

DIN EN ISO
9001/14001