

- 2-wire FTT-10A LONWORKS® bus interface
- LonMark® certified
- Easily-accessible service button and service LED
- Application can be configured to user-specific needs via LNS™-based plug-in
- Applications can be downloaded via LonWorks into flash memory (thus increasing flexibility)
- Inputs / outputs can be freely assigned

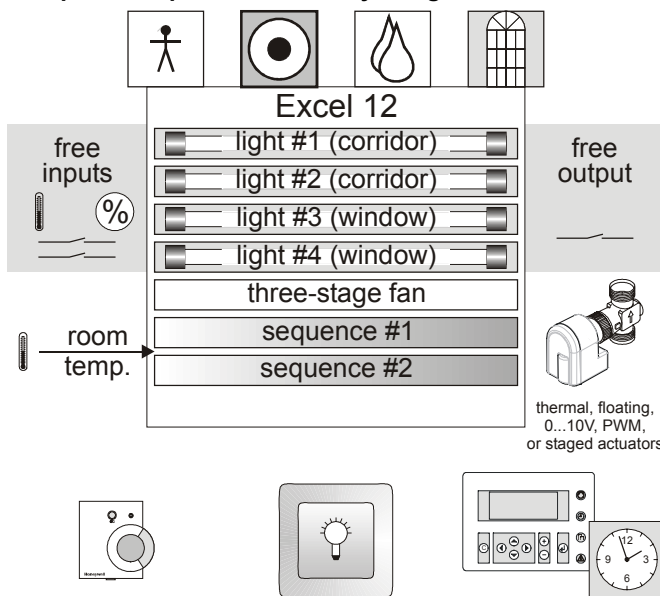

Fig. 1. Functional overview

## FEATURES

- Two-in-one controller for HVAC and lighting reduces hardware costs and engineering effort (one LONWORKS® node instead of two)
- HVAC application supports two sequences (heat, cool, or change-over)
- Light application supports four lamps. Up to two of the four light loops can be for constant light control. Light switching can be done depending on light level and occupancy (configurable via plug-in)
- Unused inputs can be used for monitoring. This application supports the following free inputs
- One unused binary output (relay or triac) can be switched via LONWORKS
- Different kinds of HVAC actuators (PWM, thermal, staged, floating, or analog) are supported
- DIN rail (wiring cabinet / fuse box) mounting and wall-mounting supported
- Different power supply variants available
- Optional terminal protection covers for wall mounting
- Optional swivel label holders for wiring information

## GENERAL

The Excel 12 FCU + 4 Lights application is LONMARK® certified, and can thus be used in all open LONWORKS® environments.

Excel 12 supports the following LONMARK® objects:

- 1 Node Object (LONMARK® object type #0)
- 4 Lamp Actuator Objects (profile #3040)
- 1 Occupancy Sensor Object (profile #1060)
- 1 Open Loop Sensor Object (LONMARK® object type #1)
- 1 Switch Object (profile #3200)
- 1 Space Comfort Controller Fan Coil Object (object type #8501)
- 1 Analog Input Object (profile #0520)
- 1 Open Loop Actuator Object (profile #3)

A variety of hardware models are available, with different I/O mixes and different line power supplies.

Page 5 provides a detailed overview of the available models. Select the model fitting your particular needs.

The application can be downloaded into the Excel 12's FLASH memory.

Honeywell's LNS™ plug-in allows you to configure the application to match your specific requirements (e.g. configure the heating / cooling sequences, the light functionality and usage of otherwise unused inputs for monitoring according to your needs).

## APPLICATION

The Excel 12 FCU + 4 Lights application supports two HVAC sequences (HEAT, COOL, or CHANGEOVER), free inputs, 1 free binary output, and up to four lights.

The application is delivered together with the plug-in and must be downloaded into the Excel 12 controller's flash memory during start-up. The user can customize the application using Honeywell's LNS™ plug-in with CARE or any LNS™ tool (e.g. LonMaker for Windows™). Customizations can be saved / reloaded for easy configuration of multiple devices.

## Application Overview

### HVAC Application:

- Two sequences configurable for HEAT, COOL, and CHANGEOVER
- Support of thermal actuators, floating actuators, PWM, 0...10 Vdc, and staged output via triac outputs or relay outputs
- 3-stage fan via triac outputs or relay outputs
- Binary inputs for condensation, occupancy sensor, window contact, etc.
- Relative or absolute temperature setting via wall module.

### Light Application:

- Four times ON / OFF switching dependent on:
  - Occupancy
  - Internal light level.  
The light will be switched ON if the light level drops below the "dark level" and it will be switched OFF if it increases above the "bright level". The "dark level" and the "bright level" can be configured via the plug-in.
  - Manual switching (via hardwired switches or LONWORKS® wall module)
- Two times dimming / constant light control for two lights with just one sensor. Dimming / constant light control is performed via analog outputs (this requires a High-Frequency Device for dimming with 1...10 Vdc input). An additional relay is required to switch the light ON/OFF.  
Constant light control helps to save additional energy. Fluorescent tubes normally lose about 15% of their brightness over their lifecycle. To compensate for this, rooms are therefore usually equipped with 15% more illumination than actually necessary. With constant light control, the light level needs to be only 85% in order to achieve the required brightness. Further savings and comfort can be achieved if there is a constant light level in the room and the light is automatically dimmed when more outside light enters. The Excel 12 supports window correction to reduce the light output of the window light. This functionality can be configured via the plug-in.
- Grouping of lights, e.g. switch four lights via a single push button.
- Soft ON/OFF switching for dimmable lamps.
- Light sensor  
The light intensities typically encountered in everyday life are listed in Table 1, while Table 2 presents the recommended light levels in various environments as set forth by DIN5035.

**NOTE:** One lux is equivalent to 0.0929 foot-candle.  
Refer also to the plug-in help information for details.

**Table 1. Typical light intensities**

| ambient conditions    | intensity (lux) |
|-----------------------|-----------------|
| summer day, cloudless | 100,000         |
| summer day, cloudy    | 20,000          |
| winter day, cloudy    | 400             |
| night, with full moon | 0.3             |

**Table 2. Recommended light intensities (DIN5035)**

| area                                   | intensity (lux) |
|--|-----------------|
| storage rooms                          | 50...200        |
| washrooms, cloakrooms, corridors, etc. | 100             |
| office rooms (near windows)            | 300             |
| office rooms (minimal outside light)   | 500             |
| open-plan office rooms                 | 750             |
| schools (daytime)                      | 300             |
| night schools                          | 500             |
| gymnasiums                             | 200             |
| show rooms                             | 300             |
| commercial kitchens                    | 500             |

**NOTE:** The intensity level depends on the sensor type and the mounting location.

**NOTE:** The indoor light sensor must be suitable for sensing artificial light, and should be mounted more towards the corridor.

### Free Inputs for Monitoring:

- Unused inputs can be used for monitoring. This application supports the following free inputs:
  - one temperature input (NTC20k; nvoAiTemp)
  - one percentage input (0..10 V or 2..10 V; nvoAiValuePct)
  - two binary inputs (nvoDiSwitch[0/1])

### Free Binary Output Can Be Switched Via LonWorks:

- One unused binary output (triac or relay outputs) may be switched via LONWORKS® (nviFreeOutput).

### Occupancy Modes:

- **Occupied mode:** The Excel 12 operates according to the "occupied" heating and cooling set-points.
- **Bypass:** After the bypass button of a hardwired wall module has been pressed or when corresponding data is received via the LONWORKS® network, the Excel 12 operates temporarily according to the "occupied" heating and cooling set-points. When the bypass time has elapsed, the controller reverts to scheduled mode. The bypass time can be configured via plug-in.
- **Standby mode:** The Excel 12 operates according to the "standby" heating and cooling set-points.
- **Unoccupied mode:** The Excel 12 operates according to the "unoccupied" heating and cooling set-points.

- **Occupancy sensor:** The occupancy sensor is used for the HVAC and light application. Hardwired and LONWORKS® occupancy sensors are supported. The occupancy sensor determines the effective occupancy mode during scheduled occupied periods (time program with occupancy schedule runs on a different controller connected to the LONWORKS® network). Depending upon the actual occupancy sensor state, the effective mode will be either "occupied" or "standby."

**Wall Modules:**

- LONWORKS® wall modules
- Hardwired wall modules (e.g. T7460, T7560)
- Wireless wall modules (e.g. W7070+T7270 or RT7070)

**Master / Slave Functionality:**

The master / slave functionality allows easy adaptation to changed room usage.

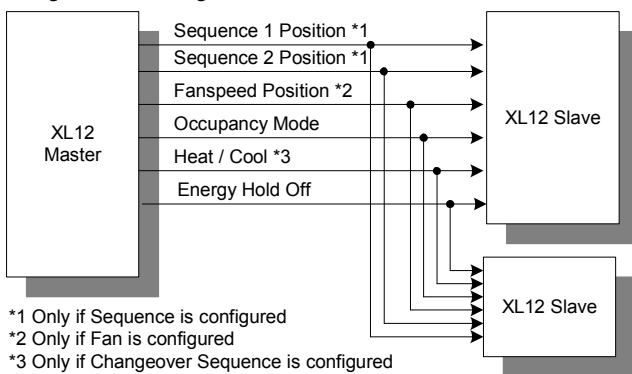

**Fig. 2. Master / Slave functionality**

**Benefits of Integrated Room Control**

The Excel 12 functionality provides you with a number of significant advantages:

- **Considerable Reduction in Energy Consumption:**
  - 25...75% savings on electrical energy consumption for illumination.
  - Decreased heat generated by electric lights, thus reducing cooling energy requirements.

**Increased Convenience:**

- Occupancy sensor switches the light ON/OFF automatically.
- Constant light control always provides the correct lighting.
- Wireless control via ZAPP (see ZAPP System Engineering, EN0B-0286GE51).

**Increased Flexibility:**

- Flexible room usage if a LONWORKS® wall module or ZAPP (remote control) is used.

**Reduced Engineering Effort / Expenses:**

- Just one LONWORKS® node (instead of two) is required to cover HVAC and Light.

- + reduced engineering and installation effort (e.g. wiring, binding, commissioning, etc.)
- + reduced integration effort
- + lower cost due to reduced number of LNS™ credits
- + lower hardware total loop costs

**INTEROPERABILITY**

The Excel 12 has been certified as per LONMARK® Application Layer Guidelines V 3.3. and is thus interoperable with all other devices in open LONWORKS® networks (including third-party devices).

**Device Configuration**

The controller is configured using Honeywell's LNS™ plug-in. The plug-in can be started from CARE 4.0 or any LNS™ tool (e.g. LonMaker for Windows™).

**LONMARK® Objects Network Variables**

The Excel 12 supports the following LONMARK® objects:

- one node object (see Fig. 3)
- one space comfort controller object (#8501 SCC – Fan Coil) (see Fig. 8)
- four lamp actuator objects (#3040) (see Fig. 4)
- one occupancy sensor object (#1060) (see Fig. 5)
- one open loop actuator object (#3) (see Fig. 6)

See also Tables 5 to 12 on page 7.

**Node Object**

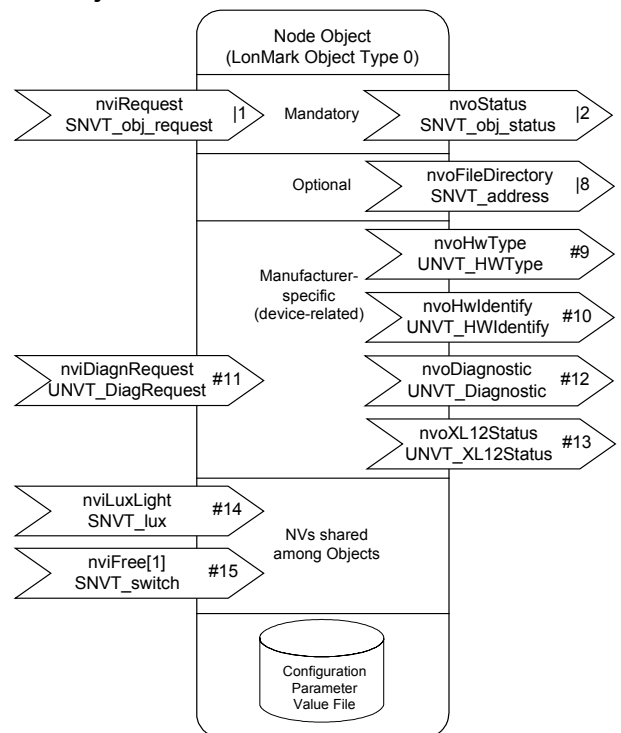

**Fig. 3. Node Object**

**Lamp Actuator Object**

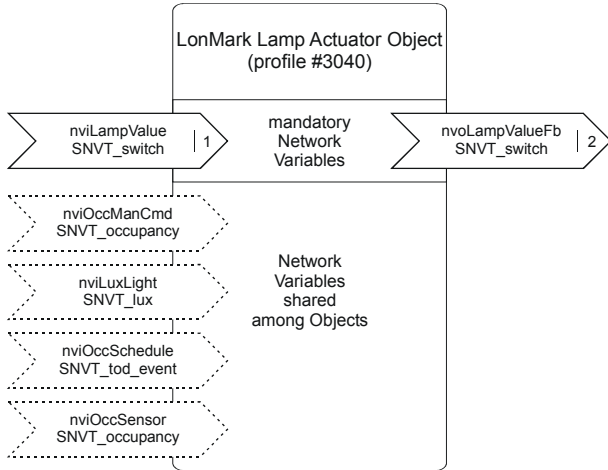

**Fig. 4. Lamp Actuator Object**

**Occupancy Sensor Object**

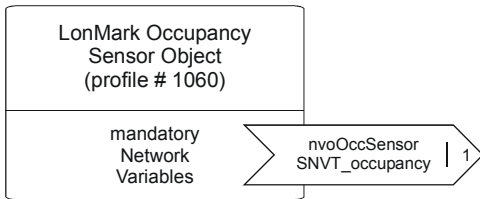

**Fig. 5. Occupancy Sensor Object**

**Open Loop Sensor Object**

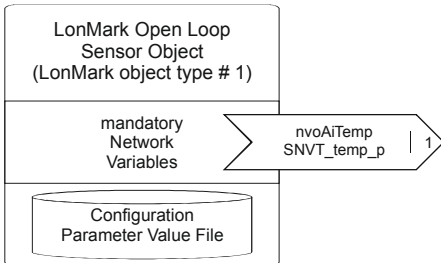

**Fig. 6. Open Loop Actuator Object**

**Switch Object**

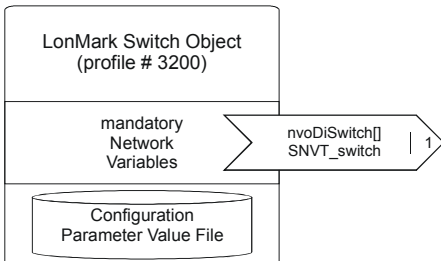

**Fig. 7. Switch Object**

**Space Comfort Controller Object**

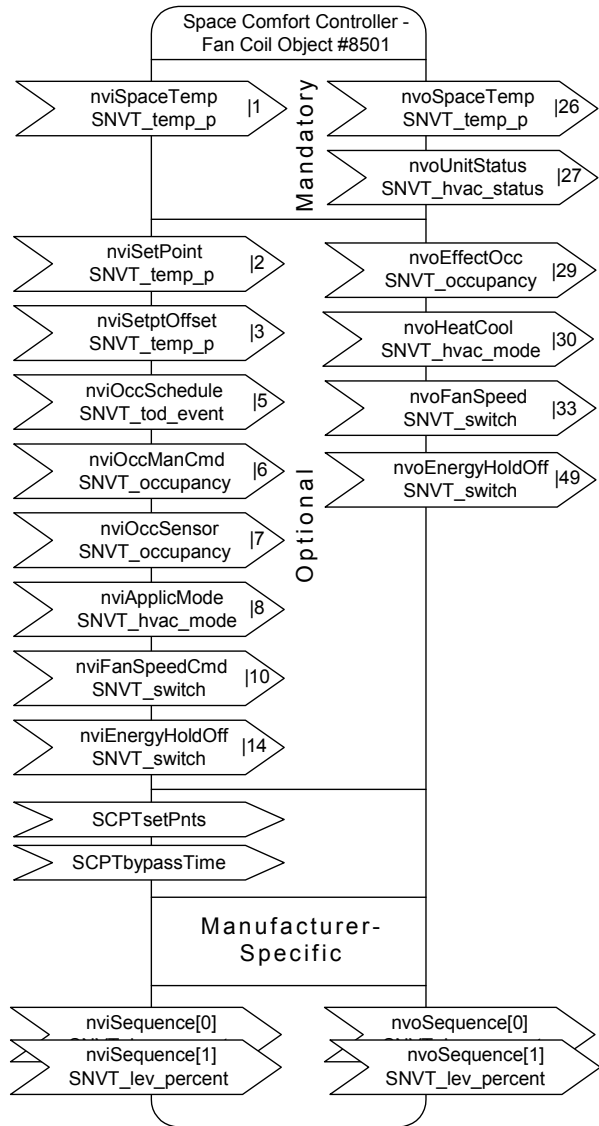

**Fig. 8. FCU Controller Object**

**Analog Input Object**

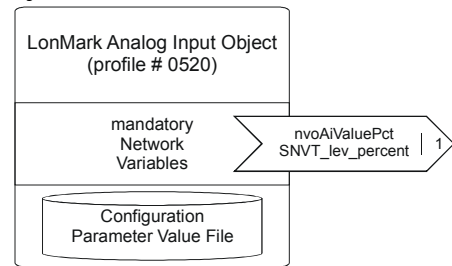

**Fig. 9. Analog Input Object**

### Open Loop Actuator Object

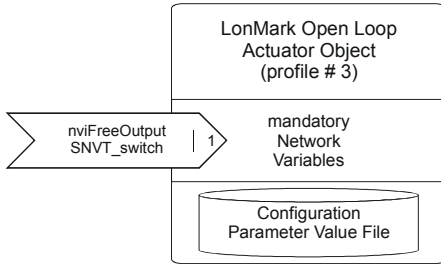

Fig. 10. Open Loop Actuator Object

### LONWORKS® Network Interface

The Excel 12 communicates within the LONWORKS® network at a rate of 78 kbs via an FTT-10A Free Topology Transceiver, which provides transformer isolation; the bus wiring is thus insensitive to polarity.

Devices so equipped can be wired in daisy chain, star, loop, or any combination thereof as long as the max. wire length requirements are met. The recommended configuration is a daisy chain with two termination modules. This layout allows for max. bus length and has the highest communication reliability, particularly when adding on to an existing bus. Refer also to <http://www.echelon.com>

### Models

Table 3. Overview of Excel 12 models

|                    | short housing | long housing | 24 Vac | 100 Vac | 230 Vac | binary input 1 | binary input 2 | binary input 3 | binary input 4 | relay 1 (N-O) | relay 2 (N-O) | relay 3 (N-O) | relay 4 (C-O) | relay 5 (C-O) | triac 1 | triac 2 | triac 3 | triac 4 | triac 5 | triac 6 | wall module LED | A11 (NTC20k + V) | A12 (NTC20k) | A13 (fan speed / | A14 (setpoint) | A15 (NTC20k + V) | A16 (NTC20k) | A16 (LESST) | A17 (NTC20k + V) | AO1 (0...10 Vdc) | AO2 (0...10 Vdc) |   |   |
|--------------------|---------------|--------------|--------|---------|---------|----------------|----------------|----------------|----------------|---------------|---------------|---------------|---------------|---------------|---------|---------|---------|---------|---------|---------|-----------------|------------------|--------------|------------------|----------------|------------------|--------------|-------------|------------------|------------------|------------------|---|---|
| <b>W7704A1004</b>  |               | X            |        |         | X       | X              | X              | X              | X              | X             | X             | X             | X             | X             | X       | X       | X       | X       | X       | X       | X               | X                | X            | X                | X              | X                | X            | X           | X                | X                | X                | X |   |
| <b>W7704B1102</b>  |               | X            |        |         | X       | X              | X              | X              | X              | X             | X             | X             | X             | X             | X       | X       | X       | X       | X       | X       | X               | X                | X            | X                | X              | X                | X            | X           | X                | X                | X                | X |   |
| <b>W7704C1000</b>  | X             |              | X      |         |         | X              | X              | X              | X              |               |               |               |               |               | X       | X       | X       | X       | X       | X       | X               | X                | X            | X                | X              | X                | X            | X           | X                | X                | X                | X |   |
| <b>W7704D1008</b>  | X             |              | X      |         |         | X              | X              | X              | X              | X             | X             | X             | X             | X             | X       | X       | X       | X       | X       | X       | X               | X                | X            | X                | X              | X                | X            | X           | X                | X                | X                | X | X |
| <b>W7704D1016</b>  |               | X            |        |         | X       | X              | X              | X              | X              | X             | X             | X             | X             | X             | X       | X       | X       | X       | X       | X       | X               | X                | X            | X                | X              | X                | X            | X           | X                | X                | X                | X | X |
| <b>W7704F1003*</b> |               | X            |        |         | X       | X              | X              | X              | X              | X             | X             | X             |               |               |         |         |         |         |         |         |                 |                  |              |                  |                |                  | X            |             | X                | X                | X                | X |   |

\* The hardware variant W7704F1003 is cost-optimized for light control and does not support a hardwired wall module.

### Long and Short Housings

Models powered with line power (W7704A, B, D1016 and F) are equipped with a built-in transformer and feature a long housing (W X L X H = 180 X 76 X 110 mm).

Models powered with 24 Vac (W7704C, and D1008) require an external 24 Vac power supply and feature a short housing (W X L X H = 126 X 76 X 110 mm).

### Binary Inputs

The Excel 12 is equipped with four dry-contact binary inputs. The binary inputs are fast (the signal must be stable for at least 25 ms). These inputs are often used for light push buttons.

### Configuration and Binding

Configuration is performed using Honeywell's LNS™ plug-in, which can be started from CARE 4.0 or any LNS™ tool (e.g. LonMaker for Windows™). Likewise, binding is performed using CARE 4.0 or any LNS™ tool.

### LONWORKS® Service Button and LED

All models feature a LONWORKS® service button (accessible from the outside on top of the module).

The service pin message is broadcast:

- whenever the LONWORKS® service button is pressed;
- after each reset due to power-up, software reset;
- if a hardwired push button for lighting is pushed for more than 10 seconds.

See also Excel 12 Installation Instructions (EN1B-0201GE51) for more-detailed information.

All models feature a LONWORKS® service LED for commissioning and troubleshooting. The service LED displays numerous different behaviors indicating various module states for use in troubleshooting (see also Excel 12 Installation Instructions).

### Binary Outputs

The triac outputs or relay outputs can be configured for different functions.

### Relay Outputs

The Excel 12 is equipped with up to two change-over (C-O) relays and up to three normally-open (N-O) relays.

### Hardware Limits

- In order to ensure a reliable contact, a min. current of 50 mA is required.
- The normally-open contacts are designed for a max. continuous current of 16 A. The normally-closed contacts are designed for a max. continuous current of 1 A.

- In order to reduce the build-up of heat in the housing, the max. combined allowable current flowing through all relays simultaneously is 24 A (continuous).
- The max. peak in-rush current (20 ms) at the normally-open contact is 80 A.

### Triac Outputs

The Excel 12 is equipped with up to six triac outputs.

#### Hardware Limits for Excel 12 with Line Power Supply

- Low signal: 0 V; high signal: 24 Vac
- **Max. 250 mA** continuous current in sum for all triac outputs together
- 550 mA for max. 10 sec.
- $\cos \varphi > 0.5$

#### Hardware Limits for Excel 12 with 24 Vac Power Supply

- Low signal: 0 V; high signal: 24 Vac
- **Max. 500 mA** continuous current in sum for all triac outputs together
- 800 mA for max. 10 sec.
- $\cos \varphi > 0.5$

**NOTE:** For controlling thermal actuators, we recommend using the 24 Vac models, which provide more current.

### Analog Outputs

The Excel 12 is equipped with up to two 0...11 Vdc analog outputs each of which can drive a max. of  $\pm 1.1$  mA.

### Analog Inputs

The Excel 12 is equipped with up to 7 analog inputs, all of which can be configured as slow binary inputs (in which case the signal must be stable for at least 1.25 sec) for the detection of a slow signals (e.g. from a window contact).

**Table 4. Analog input usage (with wall modules)**

| analog input     | voltage | NTC | wall module                      |
|------------------|---------|-----|----------------------------------|
| AI1              | X       | X   |                                  |
| AI2 <sup>4</sup> |         | X   | room temperature <sup>1</sup>    |
| AI3 <sup>4</sup> |         |     | fan speed or bypass <sup>2</sup> |
| AI4 <sup>4</sup> |         |     | set-point <sup>3</sup>           |
| AI5              | X       | X   |                                  |
| AI6              |         | X   |                                  |
| AI7              | X       | X   |                                  |

<sup>1</sup> For all NTC inputs, temperatures of  $\leq -45$  °C are interpreted as being due to a sensor break, and temperatures of  $\geq +145$  °C are interpreted as being due to a sensor short-circuit.

<sup>2</sup> A contact open for  $\geq 10$  seconds is interpreted as a sensor failure.

<sup>3</sup> A resistance of  $> 15k \Omega$  is interpreted as being due to a sensor break, a resistance of  $< 100 \Omega$  is interpreted as being due to a sensor short-circuit.

## Accessories, Standards, Ratings, Literature

### Accessories

#### Swivel Label Holders

For short or long housings (required for modules equipped with manual override switches).

- 24 Vac models (short), order no.: **XAL\_LAB\_S**
- line power supply models (long), order no.: **XAL\_LAB\_L**

#### Terminal Protection Covers

For short or long housings (required for wall/ceiling mounting).

- 24 Vac models (short), order no.: **XAL\_COV\_S**
- line power supply models (long), order no.: **XAL\_COV\_L**

#### LONWORKS® Termination

One or two LONWORKS® terminations are required, depending on the given LonWorks bus layout.

Two different LONWORKS® terminations are available:

- LONWORKS® termination module, order no.: **209541B**
- LONWORKS® connection / termination module (can be mounted on DIN rails and in fuse boxes), order no.: **XAL-Term**

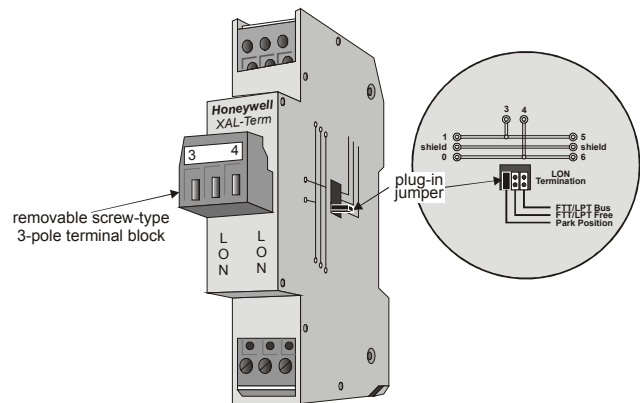

**Fig. 11. Lonworks® connection / termination module**

### Approvals and Standards

- CE and EN 50081-1
- LONMARK® Application Layer Guidelines Version 3.3

### Housings

- IP20 or IP30 (with optional terminal covers)

### Environmental Ratings

- Operating temperature: 32...122 °F (0...50 °C)
- Shipping/storage temperature: -22...158 °F (-30...70 °C)
- Relative humidity (operation and storage): 5...90%, non-condensing

### Applicable Literature

- Excel 12 Installation Instructions (EN1B-0201GE51)
- Excel 50/500 LONWORKS® Mechanisms (EN0B-0270GE51)

- Excel 10 FTT/LPT 209541B Termination Module Installation Instructions
- ZAPP System Engineering (EN0B-0286GE51)
- XL12 / XL Smart I/O Plug-in Installation Guide (EN0B-0294 GE51)
- Honeywell's XL12 / Excel Smart I/O plug-in help

## NETWORK INTERFACE

The following tables list the NV's associated with the various LONMARK® objects serving as network interfaces to the Excel 12 FCU + Light application.

**Table 5. NV's associated with the Node Object (LONMARK® object type #0)**

| name             | type             | heartbeat |
|------------------|------------------|-----------|
| nviRequest       | SNVT_obj_request | no        |
| nviLuxLight      | SNVT_lux         | no        |
| nviFree[1]       | SNVT_switch      | no        |
| nviDiagnRequest  | UNVT_DiagRequest | no        |
| nvoDiagnostic    | UNVT_Diagnostic  | no        |
| nvoStatus        | SNVT_obj_status  | yes       |
| nvoXL12Status    | UNVT_XL12Status  | no        |
| nvoFileDirectory | SNVT_address     | no        |
| nvoHwType        | UNVT_HwType      | n/a       |
| nvoHwIdentify    | UNVT_HWIdentify  | n/a       |

**Table 6. NV's associated with Lamp Actuator Object (profile #3040)**

| name              | type        | heartbeat |
|-------------------|-------------|-----------|
| nviLampValue[4]   | SNVT_switch | no        |
| nvoLampValueFb[4] | SNVT_switch | no        |

**Table 7. NV's associated with Occupancy Sensor Object (profile #1060)**

| name         | type           | heartbeat |
|--------------|----------------|-----------|
| nvoOccSensor | SNVT_occupancy | yes       |

**Table 8. NV's associated with Open Loop Sensor Object (LonMark® object type #1)**

| name         | type        | heartbeat |
|--------------|-------------|-----------|
| nvoAiTemp[1] | SNVT_temp_p | yes       |

**Table 9. NV's associated with Switch Object (profile # 3200)**

| name           | type        | heartbeat |
|----------------|-------------|-----------|
| nvoDiSwitch[2] | SNVT_switch | no        |

**Table 10. NV's associated with Space Comfort Controller FCU Object (profile # 8051)**

| Name             | type             | heartbeat |
|------------------|------------------|-----------|
| nviSpaceTemp     | SNVT_temp_p      | yes       |
| nviSetPoint      | SNVT_temp_p      | no        |
| nviSetptOffset   | SNVT_temp_p      | yes       |
| nviOccSchedule   | SNVT_tod_event   | yes       |
| nviOccManCmd     | SNVT_occupancy   | no        |
| nviOccSensor     | SNVT_occupancy   | yes       |
| nviApplicMode    | SNVT_hvac_mode   | yes       |
| nviFanSpeedCmd   | SNVT_switch      | no        |
| nviEnergyHoldOff | SNVT_switch      | yes       |
| nviSequence[2]   | SNVT_lev_percent | yes       |
| nvoSequence[2]   | SNVT_lev_percent | yes       |
| nvoSpaceTemp     | SNVT_temp_p      | yes       |
| nvoUnitStatus    | SNVT_hvac_status | yes       |
| nvoEffectOcc     | SNVT_occupancy   | no        |
| nvoHeatCool      | SNVT_hvac_mode   | yes       |
| nvoFanSpeed      | SNVT_switch      | yes       |
| nvoEnergyHoldOff | SNVT_switch      | yes       |

**Table 11. NV's associated with Analog Input Object (profile # 0520)**

| name             | type             | heartbeat |
|------------------|------------------|-----------|
| nvoAiValuePct[1] | SNVT_lev_percent | yes       |

**Table 12. NV's associated with Open Loop Actuator Object (profile #3)**

| name             | type        | heartbeat |
|------------------|-------------|-----------|
| nviFreeOutput[1] | SNVT_switch | no        |

**NOTE:** Device Resource Files are included in the plug-in package and facilitate the handling of UNVTs

## DIMENSIONS

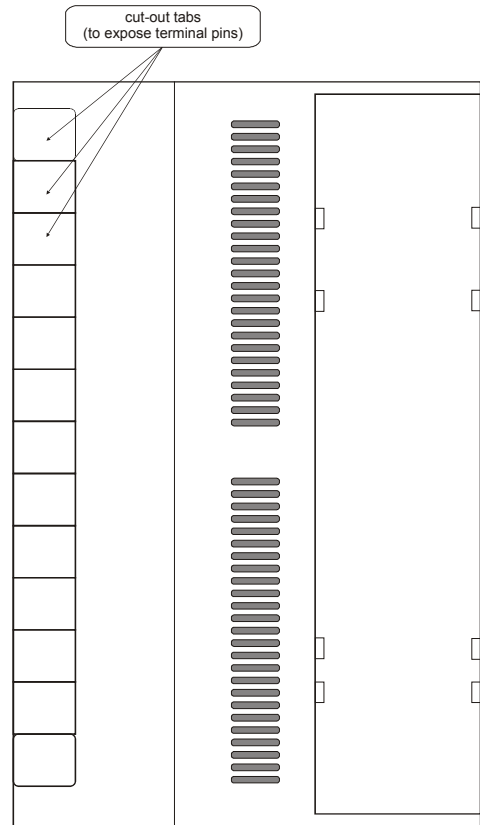
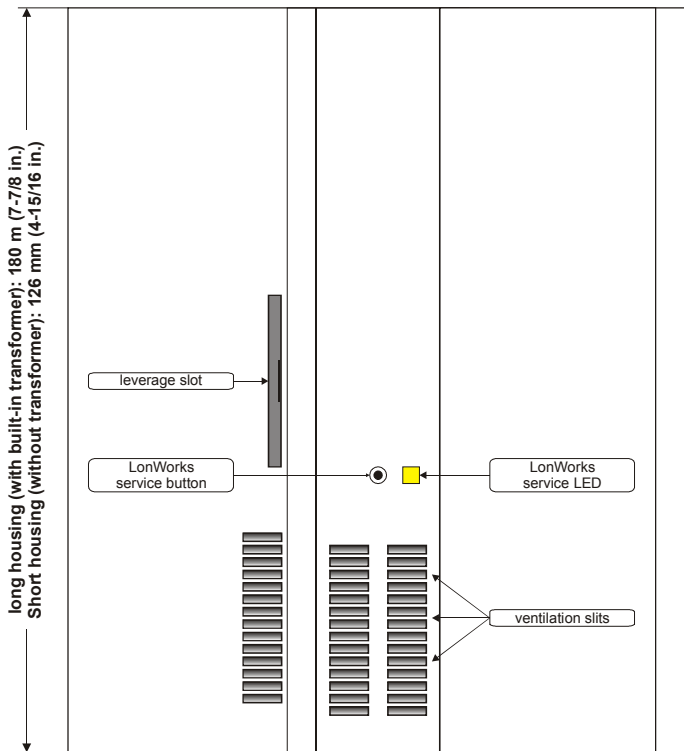
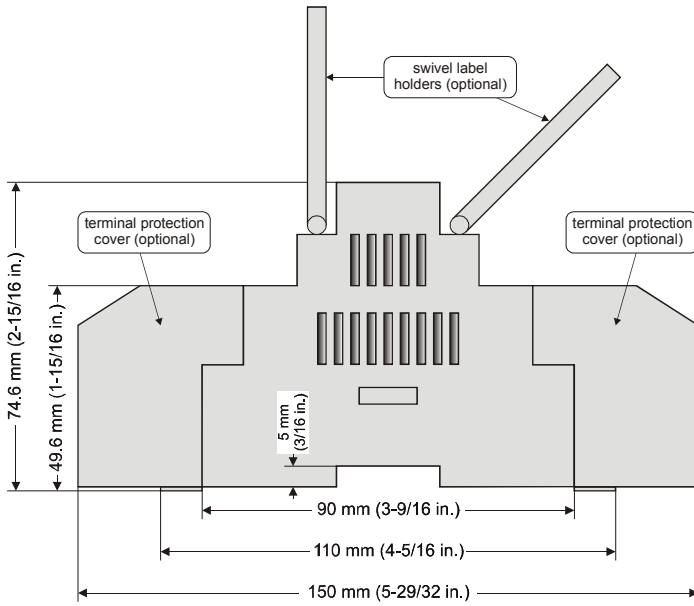

**Honeywell**

### Automation and Control Solutions

Honeywell GmbH  
 Böblinger Straße 17  
 D-71101 Schönaich  
 Phone: (49) 7031 63701  
 Fax: (49) 7031 637493  
<http://europe.hbc.honeywell.com>

Subject to change without notice. Printed in Germany

Manufacturing location certified to

**DIN EN ISO  
 9001/14001**

EN0B-0480GE51 R1004