

## N0524/N1024, N05230-2POS/N10230-2POS NON-SPRING RETURN DIRECT-COUPLED DAMPER ACTUATORS FOR FLOATING AND 2-POSITION CONTROL

### PRODUCT DATA



### GENERAL

This non-spring return direct-coupled damper actuator provides floating and two-position control for:

- air dampers,
- VAV units,
- air handlers,
- ventilation flaps,
- louvers, and
- reliable control for air damper applications with up to 1 m<sup>2</sup> / (5 Nm) and 2 m<sup>2</sup> (10 Nm) (seal-less damper blades; air friction-dependent).

### FEATURES

- **Declutch for manual adjustment**
- **Adjustable mechanical end limits**
- **Removable access cover for direct wiring**
- **Mountable in any orientation**
- **Rotation direction and service/OFF switch**

### SPECIFICATIONS

#### Supply voltage

N0524/N1024	24 Vac/dc -15%/+20%, 50/60 Hz
N05230-2POS/N10230-2POS	230 Vac -15%/+20%, 50/60 Hz

#### Nominal voltage

N0524/N1024	24 Vac/dc, 50/60 Hz
N05230-2POS/N10230-2POS	230 Vac, 50/60 Hz

**All values stated hereinafter apply to operation under nominal voltage conditions.**

#### Power consumption

N0524/N1024	5 VA / 2 W
N05230-2POS	22 VA / 2 W at 50 Hz 25 VA / 2 W at 60 Hz
N10230-2POS	22 VA / 2 W at 50 Hz 25 VA / 2 W at 60 Hz

#### Ambient limits

Ambient operating limits	-20...+60 °C (-5...+140 °F)
Ambient storage limits	-30...+80 °C (-22...+176 °F)
Relative humidity	5...95%, non-condensing

#### Safety

Protection standard	IP54
Protection class	II as per EN 60730-1
Overvoltage category	II

#### Lifetime

Full strokes	60000
Repositions	1.5 million

#### Mounting

Round damper shaft	8...16 mm
Square damper shaft	6...13 mm; 45° steps
Shaft length	min. 41 mm

#### End switches (when included)

Rating	5 A (resistive), 3 A (inductive)
Triggering points	5° / 85°

#### Torque rating

	5 Nm / 10 Nm
--	--------------

#### Runtime for 90°

N0524 / N1024	90 sec (dc / 60 Hz ac)
N0524 / N1024	110 sec (50 Hz ac)
N05230-2POS	65...110 s (60/50 Hz)
N10230-2POS	65...140 s (60/50 Hz)

#### Rotation stroke

	95° ± 3°
--	----------

#### Dimensions

	see "Dimensions" on page 6
--	----------------------------

#### Weight (without cables)

	450 g
--	-------

#### Noise rating

	35 dB(A) max. at 1 m; 40 dB(A) for 230 Vac at 65 sec runtime
--	--

## PRODUCT IDENTIFICATION SYSTEM

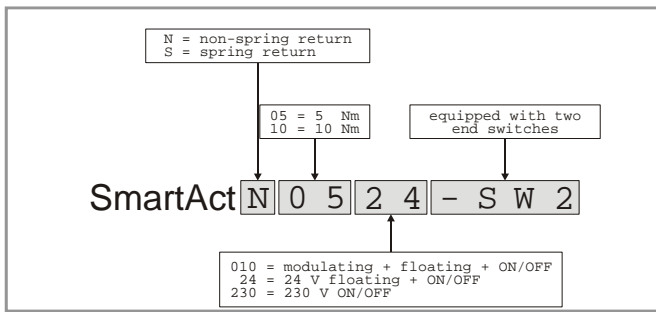

Fig. 1. Product Identification System

## MODELS

order no.	supply voltage	end switches	torque
N05024	24 Vac/dc	--	5 Nm
N05024-SW2		2	
N1024		--	10 Nm
N1024-SW2	2		
N05230-2POS	230 Vac	--	5 Nm
N10230-2POS		--	10 Nm

## BASIC FEATURES

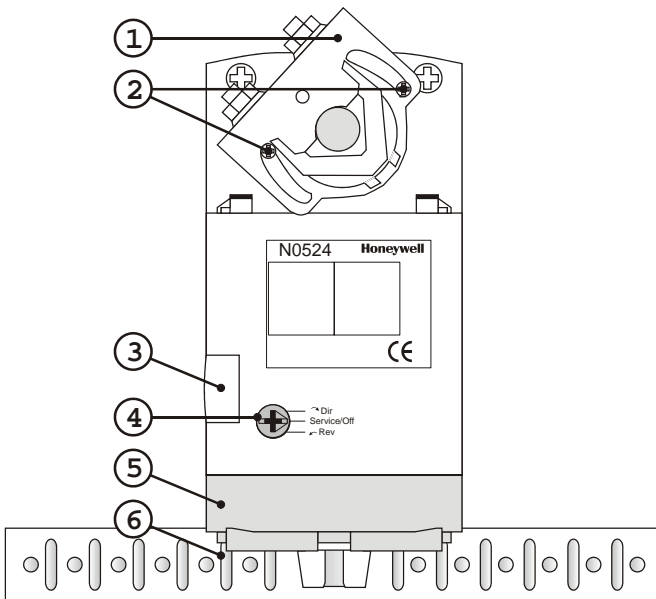

Fig. 2. Setting units and control elements

### Legend for Fig. 2:

- 1) Universal shaft adapter
- 2) Mechanical end limits (manually adjustable)
- 3) Declutch button
- 4) Function selection switch
- 5) Removable access cover
- 6) Anti-rotation bracket

## Contents of Package

The delivery package includes the actuator and parts 1 through 6 (see Fig. 2), plus two cable grommets and a spare cable grommet.

## RUN MODES

The function selection switch (see Fig. 3) can be used to place the actuator into either of two different modes:

- Service/Off; or
- the floating/2-position run mode ("Dir" for CCW-closing dampers or "Rev" for CW-closing dampers).

floating/2-position

Service / Off

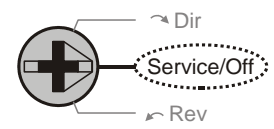
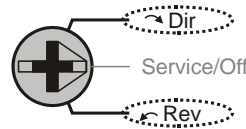

Fig. 3. Function selection switch

## Power-Off Behavior

If power is removed, the shaft adapter remains in position.

## Service/Off

If the function selection switch is set to the "Service/Off" position, then all rotary movement is cancelled, and all control signals are ignored, thus allowing the actuator to be manually operated safely.

## Floating/2-Position Run Mode

If the function selection switch has been set to one of the two floating/2-position control settings – and if the actuator is wired correspondingly (see Fig. 8, Fig. 9, and Fig. 10) – then as soon as operating power is applied, the shaft adapter will run according to the control signals applied.

Table 1 describes the behavior ("stops," rotates "CCW," or rotates "CW") of the N0524 / N1024 in dependence upon the control signals (switch "open" or "24 Vac/dc") applied to terminals 3 and 4, the function selection switch setting, and the manner in which the actuator is wired (either for floating mode: see Fig. 8; or for 2-position mode: see Fig. 9).

Table 1. Behavior of N0524/N1024

wiring	control signal at		switch setting		
	term. 3	term. 4	Dir	Service/Off	Rev
float.	open	open	stops	stops	stops
	open	24Vac/dc	CCW	stops	CW
	24Vac/dc	open	CW	stops	CCW
2-pos.	24Vac/dc	open	CW	stops	CCW
	24Vac/dc	24Vac/dc	CCW	stops	CW

Table 2 describes the behavior ("stops," rotates "CCW," or rotates "CW") of the N05230-2POS / N10230-2POS in dependence upon the control signals (switch "open" or "230 Vac") applied to terminals 1 and 3 and the function

selection switch setting; only one manner of wiring is permitted (see Fig. 10).

**Table 2. Behavior of N05230-2POS/N10230-2POS**

control signal at		switch setting		
terminal 1	terminal 3	Dir	Service/Off	Rev
open	open	stops	stops	stops
open	230 Vac	stops	stops	stops
230 Vac	open	CW	stops	CCW
230 Vac	230 Vac	CCW	stops	CW

## MANUAL ADJUSTMENT

### IMPORTANT

To prevent equipment damage, before manual adjustment, you must remove power or set the function selection switch to the "Service/Off" position.

After removing power or setting the function selection switch to the "Service/Off" position, the gear train can be disengaged using the declutch button, permitting the shaft adapter to be manually rotated to any position.

### Limitation of Rotation Stroke

Two adjustable mechanical end limits are provided to limit the angle of rotation as desired (see Fig. 4). The mechanical end limits must be securely fastened in place.

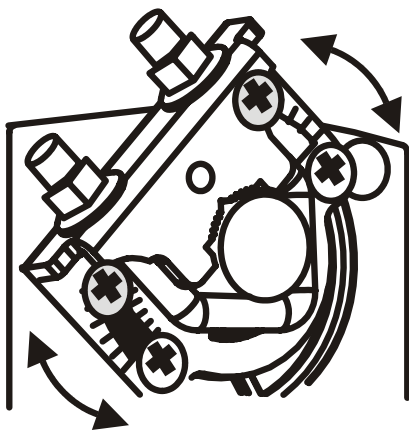

**Fig. 4. Mechanical end limits**

To ensure tight closing of the dampers, the shaft adapter has a total rotation stroke of 95°.

## INTERNAL END SWITCHES

**NOTE:** Only those actuators for which "-SW2" has been specified when ordering (e.g.: "N0524-SW2") feature internal end switches.

The internal end switches "A" and "B" are changeover switches which are activated when the shaft adapter moves past a position of 5° and 85°, respectively (see also Table 5).

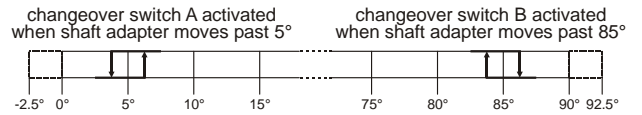

**Fig. 5. Internal end switch triggering points**

## INSTALLATION

### CAUTION

To avoid personal injury (electrical shock) and to prevent equipment damage, before installation, you must remove power.

These actuators are designed for single-point mounting.

### Mounting Instructions

All information and steps are included in the Installation Instructions (Product Literature No.: MU1B-0276GE51) supplied with each actuator.

### Mounting Position

The actuators can be mounted in any position (IP54 is dependent upon orientation; see Fig. 6). Choose a mounting position permitting easy access to cables and controls.

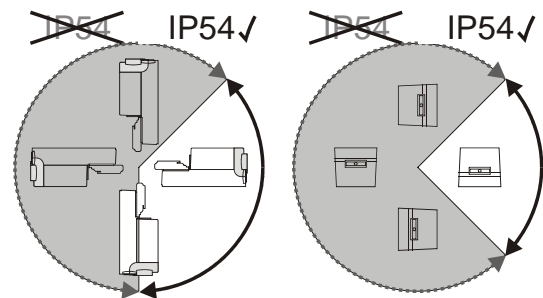

**Fig. 6. Mounting for IP54**

**NOTE:** Further, in order to guarantee IP54, only original Honeywell grommets may be used.

### Anti-Rotation Bracket and Screws

If the actuator is to be mounted directly on a damper shaft, use the anti-rotation bracket and screws included in the delivery package. The min. distance between the center of the damper shaft and the middle of the anti-rotation bracket is 85 mm; a max. of 108 mm is allowed (see also Fig. 12).

Depending upon your mounting site, the actuator may shift in position slightly while tightening the screws at the top of the shaft adapter. The anti-rotation bracket features a T-piece with a 5-mm-long shank to accommodate for this movement. It is important to ensure that this play is not impeded.

### Universal Shaft Adapter

The shaft adapter can be used for shafts of various diameters and shapes (round: 8...16 mm and square: 6...13 mm).

## WIRING

### CAUTION

To avoid personal injury (electrical shock) and to prevent equipment damage, before wiring, you must remove power.

### Connecting to the Power Supply

In order to comply with protection class II, the power source of 24 V actuators must be reliably separated from the network power supply circuits as per DIN VDE 0106, part 101.

### Access Cover

### IMPORTANT

Once the access cover has been removed, please take care to avoid damaging any of the parts now accessible.

The access cover can be unscrewed and removed in order to gain access to the terminal block(s) and perform wiring.

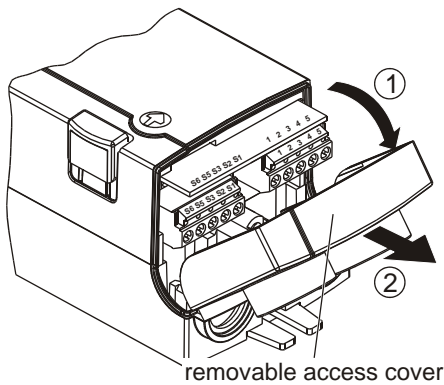

Fig. 7. Access cover

### Wiring Diagrams

Floating: Dir ↻

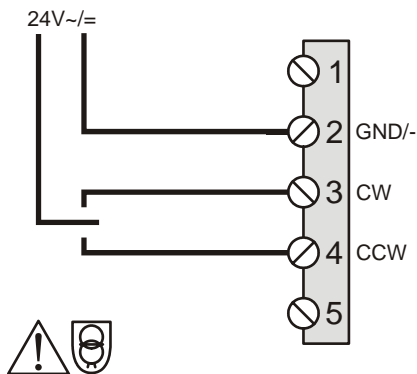

Fig. 8. N0524/N1024 (floating mode)

2-Position: Dir ↻

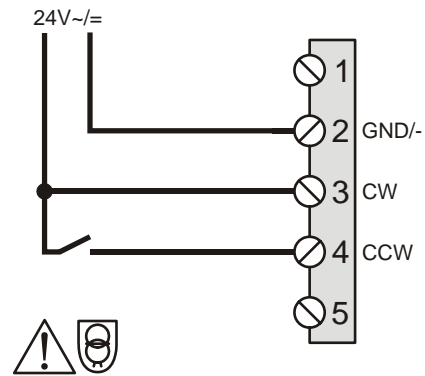

Fig. 9. N0524/N1024 (2-position mode)

2-Position: Dir ↻

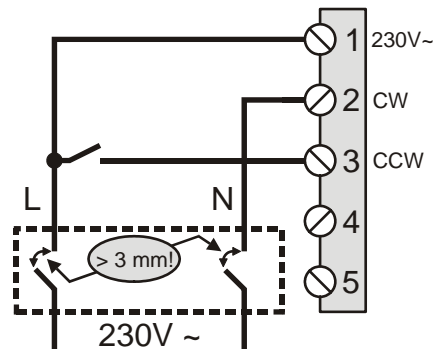

Fig. 10. N05230-2POS/N10230-2POS (2-position mode)

END SWITCHES  
(max. 230 V, 5 A)

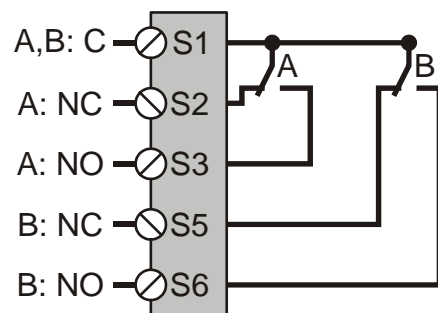

Fig. 11. End switches (Nxx-SW2)

**NOTE:** Both internal end switches must be connected to the same power source.

Table 3, Table 4, and Table 5 summarize the information presented in the preceding wiring diagrams.

**Table 3. Signals at terminals for N0524/N1024**

terminal	signal in floating mode	signal in 2-pos. mode
2	common ~/-	common ~/-
3	24 V ~/+ (control signal)	24 V ~/+ (control / power signal)
4	24 V ~/+ (control signal)	24 V ~/+ (control / power signal)
<b>NOTE:</b> All cables connected to these terminals must be equipped with spark suppression.		

**Table 4. Signals at terminals for N05230-2POS/N10230-2POS (2-position mode, only)**

terminal	signal
1	L (230 V ~)
2	N (230 V ~)
3	control signal
<b>NOTE:</b> All cables connected to these terminals must be equipped with spark suppression.	

**Table 5. Internal end switches (Nxx-SW2)**

terminal	type of switch
S1	common lead for switches A and B
S2 / S3	change-over switch A (S1/S2 opens and S1/S3 closes when shaft adapter moves CW past 5°; reverts to original state when shaft adapter moves CCW past 5°).
S5 / S6	change-over switch B (S1/S5 opens and S1/S6 closes when shaft adapter moves CW past 85°; reverts to original state when shaft adapter moves CCW past 85°).

## SPARE PARTS

### Anti-Rotation Bracket Kit

Order no.: A7211.2073



Contains:

- 10 anti-rotation brackets
- 20 screws

### Spare Parts Kit

Order no.: A7211.2071

Contains:

- 1 anti-rotation bracket + screws
- 2 universal terminal blocks
- 2 strain-relief clamps
- 2 grommets\*
- 2 adjustable end stops

\*In order to guarantee IP54, only original Honeywell grommets may be used.



## DIMENSIONS

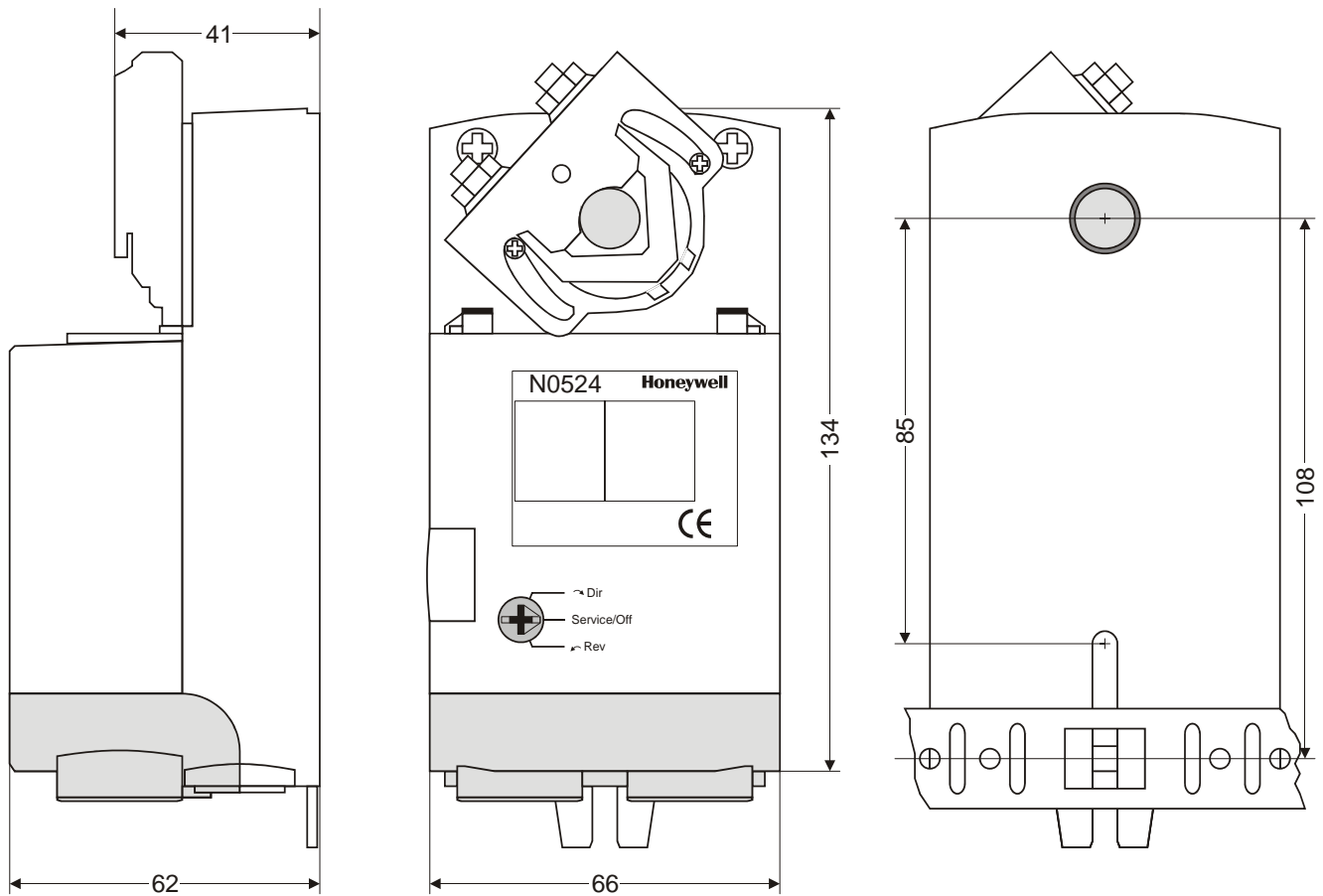

Fig. 12. Dimensions (in mm)

**Honeywell**

### Automation and Control Solutions

Honeywell GmbH  
 Böblinger Straße 17  
 D-71101 Schönaich  
 Phone: (49) 7031 63701  
 Fax: (49) 7031 637493  
<http://europe.hbc.honeywell.com>

Subject to change without notice. Printed in Germany

Manufacturing location certified to **DIN EN ISO 9001**

EN0B-0477GE51 R0105